

VARIETIES OF POSITIVE MODAL ALGEBRAS AND STRUCTURAL COMPLETENESS

TOMMASO MORASCHINI

ABSTRACT. Positive modal algebras are the $\langle \wedge, \vee, \diamond, \Box, 0, 1 \rangle$ -subreducts of modal algebras. We prove that the variety of positive S_4 -algebras is not locally finite. On the other hand, the free one-generated positive S_4 -algebra is shown to be finite. Moreover, we describe the bottom part of the lattice of varieties of positive S_4 -algebras. Building on this, we characterize (passively, hereditarily) structurally complete varieties of positive K_4 -algebras.

1. INTRODUCTION

In recent years, subclassical fragments of modal logics have attracted some attention because of their balance between expressive power and lower computational complexity [2, 3, 45, 46]. Among these subclassical fragments, a special role is played by the *positive modal logic* PML [19], i.e. the $\langle \wedge, \vee, \Box, \diamond, 0, 1 \rangle$ -fragment of the local consequence of the normal modal logic K [7, 13, 28, 36]. The interest of PML and its extensions comes from the fact that, despite their restricted signature, they preserve some mathematically desirable features typical of normal modal logics, including Sahlqvist theory and a well-behaved Priestley-style duality [10, 11, 25]. For similar reasons, PML and their generalizations were studied both from the perspective of algebraic logic [30] and from that of coalgebra [1, 48].

When suitably reformulated as a Gentzen system \mathcal{PML} as in [10], the logic PML becomes *algebraizable* in the sense of [51, 55] (see the Appendix for a more detailed discussion). In particular, the algebraic counterpart of \mathcal{PML} is the class of the so-called *positive modal algebras* [19], i.e. positive subreducts of classical modal algebras, which turn out to form a variety (or, equivalently, by Birkhoff's theorem, an equational class). As a consequence of algebraizability, there is a dual lattice isomorphism between the lattice of axiomatic extensions of \mathcal{PML} and that of subvarieties of positive modal algebras. Thus axiomatic extensions of \mathcal{PML} can be studied through the lenses of varieties of positive modal algebras, which in turn are amenable to the methods of universal algebra [5, 9, 41]. Driven by this observation,

Key words Positive modal logic, modal logic, structural completeness, admissible rule, abstract algebraic logic, algebraization of Gentzen systems

Date: June 10, 2019.

in this paper we initiate the study of the lattice of subvarieties of positive modal algebras. Since its structure is largely unknown, we focus on the more definite goal of describing its *structurally complete* members.

For a general background on structural completeness we refer the reader to [52, 58]. Even if structural completeness is usually understood as a property of logics and not, strictly speaking, of classes of algebras, we find it convenient to introduce this and some related concepts in purely algebraic terms as in [4]. Let K be a quasi-variety, and consider a quasi-equation

$$\Phi := \varphi_1 \approx \psi_1 \& \dots \& \varphi_n \approx \psi_n \rightarrow \varphi \approx \psi.$$

The quasi-equation Φ is *active* in K when there is a substitution σ such that $K \models \sigma\varphi_i \approx \sigma\psi_i$ for every $i \leq n$. The quasi-equation Φ is *passive* in K if it is not active in K . The quasi-equation Φ is *admissible* in K if for all substitutions σ :

$$\text{if } K \models \sigma\varphi_i \approx \sigma\psi_i \text{ for every } i \leq n, \text{ then } K \models \sigma\varphi \approx \sigma\psi.$$

The quasi-equation Φ is *valid* in K if $K \models \Phi$. Accordingly, we say that

1. K is *actively structurally complete* (ASC) if every active admissible quasi-equation is valid.
2. K is *passively structurally complete* (PSC) if every passive quasi-equation is valid.¹
3. K is *structurally complete* (SC) if every admissible quasi-equation is valid.
4. K is *hereditarily structurally complete* (HSC) if every subquasi-variety of K is SC.

If \vdash is a finitary algebraizable logic or Gentzen system [8, 51, 55] with equivalent algebraic semantics a quasi-variety K , then K is structurally complete exactly when the finite admissible rules of \vdash are derivable in the usual sense. This is the case, for instance, of the Gentzen system \mathcal{PML} , which is finitary and algebraized by the variety of positive modal algebras.

The interest of variants of structural completeness is partially due to their influence on the structure of the lattices of subquasi-varieties. For instance, if a quasi-variety K is HSC, then its lattice of subquasi-varieties happens to be distributive [26, 27]. Moreover, if K is PSC, then all its subquasi-varieties have the joint embedding property [44] and, therefore, are generated as quasi-varieties by a single algebra [39]. On the other hand, variants of structural completeness are interesting also from a purely logical perspective. For instance, if a SC quasi-variety K has the finite model property (i.e. K and the class of its finite members generate the same *variety*), then K has the strong finite model property as well (i.e. it is generated *as a quasi-variety* by its finite members), as observed in [47]. Finally, ASC is known to be related to projective and exact unification [20].

In [4, 20, 43, 59] the following characterizations of the various kinds of structural completeness are obtained.

¹Observe that passive quasi-equations are vacuously admissible.

Theorem 1.1. *Let \mathbf{K} be a variety.*

1. \mathbf{K} is ASC if and only if $\mathbf{A} \times \mathbf{Fm}_{\mathbf{K}}(\omega) \in \mathbb{Q}(\mathbf{Fm}_{\mathbf{K}}(\omega))$ for every subdirectly irreducible algebra $\mathbf{A} \in \mathbf{K}$. If there is a constant symbol in the language, then we can replace “ $\mathbf{A} \times \mathbf{Fm}_{\mathbf{K}}(\omega) \in \mathbb{Q}(\mathbf{Fm}_{\mathbf{K}}(\omega))$ ” by “ $\mathbf{A} \times \mathbf{Fm}_{\mathbf{K}}(0) \in \mathbb{Q}(\mathbf{Fm}_{\mathbf{K}}(\omega))$ ” in this statement.
2. \mathbf{K} is a PSC variety if and only if every positive existential sentence is either true in all non-trivial members of \mathbf{K} or false in all non-trivial members of \mathbf{K} .
3. \mathbf{K} is SC if and only if $\mathbf{A} \in \mathbb{SP}_v(\mathbf{Fm}_{\mathbf{K}}(\omega))$ for every subdirectly irreducible algebra $\mathbf{A} \in \mathbf{K}$.
4. \mathbf{K} is HSC if and only if every subquasi-variety of \mathbf{K} is a variety.

Structural completeness and its variants have been the subject of intense research in the setting of modal and Heyting algebras [58], yielding an array of deep results. To name only a few of them, HSC varieties of \mathbf{K}_4 -algebras, and of Heyting algebras have been fully described in [57, 14]. Moreover, explicit bases for the admissible rules of intuitionistic logic (equiv. of quasi-equations admissible in the variety of Heyting algebras), and of some prominent modal systems have been provided in [29, 31]. Unfortunately, the picture of structural completeness tends to change dramatically when the set of connectives is altered (see for instance [53]). Accordingly, we should not expect, at least in principle, that results on admissibility and structural completeness valid in modal algebras could be extended directly to positive modal algebras.

Our results on structural completeness are confined to classes of *positive \mathbf{K}_4 -algebras*, i.e. positive subreducts of \mathbf{K}_4 -algebras. In this context, we show that there are exactly three non-trivial structurally complete varieties of positive \mathbf{K}_4 -algebras (Theorem 9.7). Moreover, these are also the unique hereditarily structurally complete varieties of positive \mathbf{K}_4 -algebras. This contrasts with the full-signature case, since there are infinitely (countably) many hereditarily structurally complete varieties of \mathbf{K}_4 -algebras [57]. Moreover, we characterize passively structurally complete varieties of positive \mathbf{K}_4 -algebras (Theorem 9.8) and prove that there are infinitely many of them (Example 9.9).

To establish these results, we rely on two observations concerning *positive \mathbf{S}_4 -algebras*, i.e. positive subreducts of \mathbf{S}_4 -algebras, which may be of some interest on their own. On the one hand, we show that, even if the variety of positive \mathbf{S}_4 -algebras is not locally finite (Corollary 5.4), its free one-generated algebra is finite (Theorem 5.1). This contrasts with the full-signature case, since already the one-generated free \mathbf{S}_4 -algebra is infinite [56]. On the other hand, we rely on a description of the bottom part of the lattice of subvarieties of positive \mathbf{S}_4 -algebras up to height ≤ 4 (Theorem 8.6), represented pictorially in Figure 4. From a logical point of view, this result provides a partial description of the top part of the lattice of axiomatic extensions of the Gentzen system $\mathcal{PM}\mathcal{L}$.

We hope that this work may stimulate the further investigation of varieties of positive modal algebras and of admissibility in positive modal logic, whose theory is at the moment underdeveloped. In particular, it would be interesting to find an explicit base for the admissible quasi-equations of the variety of positive K_4 -algebras, complementing for instance the results of [31].

2. PRELIMINARIES

For a general background on universal algebra we refer the reader to [5, 9, 41]. We denote by $\mathbb{I}, \mathbb{H}, \mathbb{S}, \mathbb{P}, \mathbb{P}_{\text{SD}}, \mathbb{P}_U$ the class operators of closure under isomorphism, homomorphic images, subalgebras, direct products, subdirect products and ultraproducts respectively. Given an algebra A , we denote by $\text{Con}A$ its congruence lattice and by Id_A the identity relation on A . Then A is *subdirectly irreducible* when Id_A is completely meet-irreducible in $\text{Con}A$, i.e. when the poset $\text{Con}A \setminus \{\text{Id}_A\}$ has a least element θ . In this case, the congruence θ is called the *monolith* of A . The monolith of A is always a principal congruence, in fact $\theta = \text{Cg}(a, b)$ for every $\langle a, b \rangle \in \theta$ such that $a \neq b$. Similarly, an algebra A is *finitely subdirectly irreducible* if Id_A is meet-irreducible in $\text{Con}A$. Given a class of algebras K , we denote by K_{si} the class of its subdirectly irreducible members. An algebra A is *simple* when $\text{Con}A$ has exactly two-elements.

A *variety* is a class of algebras axiomatized by equations or, equivalently, a class of algebras closed under \mathbb{H}, \mathbb{S} and \mathbb{P} . A *quasi-variety* is a class of algebras axiomatized by quasi-equations or, equivalently, a class of algebras closed under $\mathbb{I}, \mathbb{S}, \mathbb{P}$ and \mathbb{P}_U . Given a class of algebras K , we denote by $\mathbb{V}(K)$ and $\mathbb{Q}(K)$ respectively the least variety and quasi-variety containing K . It is well known that $\mathbb{V}(K) = \mathbb{HSP}(K)$ and $\mathbb{Q}(K) = \mathbb{ISP}_U(K)$. An algebra A in a quasi-variety K is *subdirectly irreducible relative* to K if the poset $\langle \{\theta \in \text{Con}A : A/\theta \in K \text{ and } \theta \neq \text{Id}_A\}, \subseteq \rangle$ has a minimum element. Every algebra in a quasi-variety K is a subdirect product of algebras subdirectly irreducible relative to K . If K is a class of algebras, then the algebras subdirectly irreducible relative to $\mathbb{Q}(K)$ belong to $\mathbb{ISP}_U(K)$ [16]. Given a quasi-variety K and $n \in \omega$, we denote by $\mathbf{Fm}_K(x_1, \dots, x_n)$ the free n -generated algebra over K . It is well known that the elements of $\mathbf{Fm}_K(x_1, \dots, x_n)$ are congruence classes of terms, which we denote by $\llbracket \varphi \rrbracket, \llbracket \psi \rrbracket$ etc. The free countably-generated algebra over K is denoted by $\mathbf{Fm}_K(\omega)$.

Let K be a class of algebras. An algebra $A \in K$ is *projective* in K if for every $B, C \in K$ and homomorphisms $f: B \rightarrow C$ and $g: A \rightarrow C$ where f is surjective, there is a homomorphism $h: A \rightarrow B$ such that $g = f \circ h$. An algebra A is a *retract* of an algebra B if there are homomorphisms $f: A \rightarrow B$ and $g: B \rightarrow A$ such that the composition $g \circ f$ is the identity map on A . It is well known that the projective algebras in a variety are exactly the retracts of free algebras.

Consider an algebra A and a sublanguage \mathcal{L} of the language of A . The \mathcal{L} -reduct of A is the algebra $\langle A, \{f^A : f \in \mathcal{L}\} \rangle$. An algebra B in language \mathcal{L} is a \mathcal{L} -subreduct of A if it can be embedded into the \mathcal{L} -reduct of A . If K is a quasi-variety and \mathcal{L} is a sublanguage of the language of K , then the class of \mathcal{L} -subreducts of algebras in K coincides with the quasi-variety generated by the \mathcal{L} -reducts of algebras in K [39].

A variety K has the *congruence extension property* (CEP) if for every $A, B \in K$ such that $B \in \mathbb{S}(A)$, if θ is a congruence of B , then there is a congruence ϕ of A such that $\phi \cap B^2 = \theta$. A variety K has *equationally definable principal congruences* (EDPC) [35] if there is a finite set of equation $\Phi(x, y, z, v)$ such that for every $A \in K$ and $a, b, c, d \in A$ we have:

$$\langle a, b \rangle \in \text{Cg}(c, d) \iff A \models \Phi(a, b, c, d).$$

It is easy to see that EDPC implies the CEP, however the converse implication does not hold in general. It is well known that both the variety of (bounded) distributive lattices and the variety of K_4 -algebras have EDPC. More precisely, given a (bounded) distributive lattice A and $a, b, c, d \in A$, we have that

$$\langle c, d \rangle \in \text{Cg}(a, b) \iff (c \wedge a \wedge b = d \wedge a \wedge b \text{ and } c \vee a \vee b = d \vee a \vee b). \quad (1)$$

Moreover, given a K_4 -algebra A and $a, b, c, d \in A$, we have that

$$\langle a, b \rangle \in \text{Cg}(c, d) \iff A \models (c \leftrightarrow d) \wedge \Box(c \leftrightarrow d) \leq a \leftrightarrow b. \quad (2)$$

Finally, we will rely on the following easy observation, which is essentially [52, Theorem 7.7].

Lemma 2.1. *If K is a PSC variety with a constant symbol, its free 0-generated algebra is either simple or trivial.*

3. ALGEBRAS AND FRAMES

The algebraic study of the positive fragment of the normal modal logic \mathbf{K} was begun by Dunn in [19], where the following algebraic models were introduced:

Definition 3.1. A *positive modal algebra* is a structure $A = \langle A, \wedge, \vee, \Box, \Diamond, 0, 1 \rangle$ where $\langle A, \wedge, \vee, 0, 1 \rangle$ is a bounded distributive lattice such that $\Box 1 = 1$ and $\Diamond 0 = 0$ and

$$\begin{aligned} \Box(a \wedge b) &= \Box a \wedge \Box b \\ \Diamond(a \vee b) &= \Diamond a \vee \Diamond b \\ \Box a \wedge \Diamond b &\leq \Diamond(a \wedge b) \\ \Box(a \vee b) &\leq \Box a \vee \Diamond b \end{aligned}$$

for every $a, b \in A$. We denote by PMA the variety of positive modal algebras. The class PMA can be endowed with the structure of a category, whose arrows are homomorphisms, and which we will denote also by PMA since no confusion shall occur.

It is worth remarking that the above equations were considered earlier by Johnstone in the study of a localic version of the Vietoris construction [32, 33].

A *Priestley space* is a triple $\langle X, \leq, \tau \rangle$, where $\langle X, \leq \rangle$ is a poset and $\langle X, \tau \rangle$ is a compact topological space, which satisfies the following additional condition: for every $x, y \in X$ such that $x \not\leq y$ there is a clopen upset U such that $x \in U$ and $y \notin U$. Priestley duality states that the category of Priestley spaces, endowed with continuous order-preserving maps, is dually equivalent to the category of bounded distributive lattices with homomorphisms [49, 50, 17]. Building on Priestley duality, Celani and Jansana presented a topological duality for positive modal algebras [11]. We will briefly review it, since it will be needed later on. Given a set X and a binary relation R on it, we let $\square_R, \diamond_R: \mathcal{P}(X) \rightarrow \mathcal{P}(X)$ be the maps defined for every $V \subseteq X$ as follows:

$$\begin{aligned}\square_R V &:= \{x \in X : \text{if } \langle x, y \rangle \in R, \text{ then } y \in V\} \\ \diamond_R V &:= \{x \in X : \text{there is } y \in X \text{ such that } \langle x, y \rangle \in R \text{ and } y \in V\}.\end{aligned}$$

Definition 3.2. A K^+ -space is a structure $\langle X, \leq, R, \tau \rangle$ where $\langle X, \leq, \tau \rangle$ is a Priestley space and R is a binary relation on X such that:

1. $R = (R \circ \leq) \cap (R \circ \leq^{-1})$.
2. The clopen upsets of τ are closed under the operations \square_R and \diamond_R .
3. The set $\{y \in X : \langle x, y \rangle \in R\}$ is topologically closed for every $x \in X$.

Definition 3.3. Let $X = \langle X, \leq^X, R^X, \tau^X \rangle$ and $Y = \langle Y, \leq^Y, R^Y, \tau^Y \rangle$ be K^+ -spaces. A *p-morphism* from X to Y is a continuous map $f: X \rightarrow Y$, that preserves \leq and R , and satisfies the following condition for every $x, y \in X$:

$$\begin{aligned}\text{if } \langle f(x), y \rangle \in R^Y, \text{ then there are } z, v \in X \text{ such that} \\ \langle x, z \rangle, \langle x, v \rangle \in R^X \text{ and } f(z) \leq y \leq f(v).\end{aligned}$$

We denote by K^+ the category of K^+ spaces endowed with *p-morphisms*.

Positive modal algebras and K^+ -spaces are related as follows. Consider $A \in \text{PMA}$ and let $\text{Pr}(A)$ be the collection of prime filters of A . Then we define a relation $R_A \subseteq \text{Pr}(A) \times \text{Pr}(A)$ as follows:

$$\langle F, G \rangle \in R_A \iff \square^{-1}(F) \subseteq G \subseteq \diamond^{-1}(F)$$

for every $F, G \in \text{Pr}(A)$. Moreover, for every $a \in A$ we set

$$\varphi(a) := \{F \in \text{Pr}(A) : a \in F\}.$$

Finally, we let τ be the topology on $\text{Pr}(A)$ generated by the following subbasis:

$$\{\varphi(a) : a \in A\} \cup \{\varphi(a)^c : a \in A\}.$$

It turns out that the structure

$$A^* := \langle \text{Pr}(A), \subseteq, R_A, \tau \rangle$$

is a K^+ -space. Moreover, if $f: A \rightarrow B$ is a homomorphism between positive modal algebras, then the map $f^*: \text{Pr}(B) \rightarrow \text{Pr}(A)$, defined for every $F \in \text{Pr}(B)$ as $f^*(F) := f^{-1}[F]$, is a p-morphism from B^* to A^* . It turns out that the application $*$: $\text{PMA} \rightarrow K^+$ is a contravariant functor.

Conversely, consider a K^+ -space X and let $\text{Up}(X)$ be the collection of clopen upsets of $\langle X, \leq, \tau \rangle$. It turns out that the structure

$$X_* := \langle \text{Up}(X), \cap, \cup, \square_R, \diamond_R, \emptyset, X \rangle$$

is a positive modal algebra. Moreover, if $f: X \rightarrow Y$ is a p-morphism between K^+ -spaces, then the map $f_*: \text{Up}(Y) \rightarrow \text{Up}(X)$, defined for every $V \in \text{Up}(Y)$ as $f_*(V) := f^{-1}[V]$, is a homomorphism from Y_* to X_* . The application $*$: $K^+ \rightarrow \text{PMA}$ is a contravariant functor as well. The relation between positive modal algebras and K^+ -spaces can be formulated as follows [11, pag. 700]:

Theorem 3.4 (Celani and Jansana). *The functors $*$: $\text{PMA} \leftarrow K^+$: $*$ from a dual category equivalence.*

The above result implies that every positive modal algebra A is isomorphic to the algebra of clopen upsets of its dual K^+ -space. More precisely, we have the following representation theorem, which is essentially [19, Theorem 8.1], but see also [11, Theorem 2.2].

Theorem 3.5 (Celani, Dunn and Jansana). *Consider $A \in \text{PMA}$. The map $\kappa: A \rightarrow (A^*)_*$ defined by the rule*

$$a \mapsto \{F \in \text{Pr}(A) : a \in F\}$$

is an isomorphism.

A useful consequence of this representation is the following correspondence result:

Corollary 3.6. *Consider $A \in \text{PMA}$.*

1. R_A is reflexive if and only if $\square a \leq a \leq \diamond a$ for every $a \in A$.
2. R_A is transitive if and only if $\square a \leq \square \square a$ and $\diamond \diamond a \leq \diamond a$ for every $a \in A$.

We will focus on the following varieties of positive modal algebras:

Definition 3.7. Let $A \in \text{PMA}$.

1. A is a positive K_4 -algebra if for every $a \in A$:

$$\square a \leq \square \square a \text{ and } \diamond \diamond a \leq \diamond a.$$

2. A is a positive S_4 -algebra if for every $a \in A$:

$$\square \square a = \square a \leq a \leq \diamond a = \diamond \diamond a.$$

We denote respectively by PK_4 and PS_4 the varieties of positive K_4 and S_4 -algebras. It is clear that $\text{PS}_4 \subseteq \text{PK}_4$.

From Theorem 3.4 and Corollary 3.6 it follows that PK4 (resp. PS4) is dually equivalent to the full subcategory K^+ , whose objects are K^+ -spaces whose relation R is transitive (resp. transitive and reflexive). This dual equivalence is witnessed by the restriction of the functors described above. The following result motivates the name of positive K_4 and S_4 -algebras:

Theorem 3.8. *PMA, PKA and PS4 are respectively the classes of $\langle \wedge, \vee, \square, \diamond, 0, 1 \rangle$ subreducts of modal, K_4 and S_4 -algebras.*

Proof. Consider $A \in \text{PMA}$ and define an algebra

$$\mathcal{M}(A) := \langle \mathcal{P}(\text{Pr}(A)), \cap, \cup, \neg, \square_{R_A}, 0, 1 \rangle$$

where \neg is the set-theoretic complement. It is very easy to see that $\mathcal{M}(A)$ is a modal algebra, and that that map $\kappa: A \rightarrow \mathcal{M}(A)$, defined in Theorem 3.5, is an embedding that respects $\langle \wedge, \vee, \square, \diamond, 0, 1 \rangle$. Thus A is a positive subreduct of a modal algebra.

Now consider $A \in \text{PK4}$. By Corollary 3.6 we know that R_A is transitive. In particular, this implies that $\mathcal{M}(A)$ is a K_4 -algebra. Thus the map $\kappa: A \rightarrow \mathcal{M}(A)$ embeds A into a K_4 -algebra preserving $\langle \wedge, \vee, \square, \diamond, 0, 1 \rangle$. We conclude that A is a positive subreduct of a K_4 -algebra. On the other hand, the equations defining PK4 hold in K_4 -algebras. Thus we conclude that PK4 is the class of positive subreducts of K_4 -algebras. The case of PS4 is handled similarly. \square

4. WELL-CONNECTED ALGEBRAS

Let A be a modal algebra. A lattice filter F of A is *open* if $a \in F$ implies $\square a \in F$ for every $a \in A$. The set of open filters of A , when ordered under the inclusion relation, forms a lattice $\text{Op}(A)$. It is well known [36] that the lattices $\text{Op}(A)$ and $\text{Con}A$ are isomorphic under the map defined by the following rule:

$$F \longmapsto \theta_F := \{ \langle a, b \rangle \in A^2 : a \rightarrow b, b \rightarrow a \in F \}.$$

An analogous correspondence holds between the congruences of A and its ideals closed under \diamond . The correspondence between open filters and congruences implies that a modal algebra A is subdirectly irreducible when the poset $\langle \text{Op}(A) \setminus \{\{1\}\}, \subseteq \rangle$ has a minimum element [54]. In some cases this condition can be shifted from subsets of the universe of A (such as open filters) to elements of A . This happens for example in S_4 -algebras.² An S_4 -algebra A is *well-connected* if $\square a \vee \square b = 1$ implies $a = 1$ or $b = 1$ for every $a, b \in A$ [42]. The correspondence between open filters and congruences implies that an S_4 -algebra is well-connected if and only if it is finitely subdirectly irreducible. Moreover, an S_4 -algebra A is simple if and only if $\square a = 0$ for every $a \neq 1$ (see [36] if necessary). The notion of well-connection can be adapted to positive S_4 -algebras as follows:

²Similar results hold for K_4 -algebras as well.

Definition 4.1. A positive S_4 -algebra A is *well-connected* when for every $a, b \in A$:

1. If $\Box a \vee \Box b = 1$, then $a = 1$ or $b = 1$.
2. If $\Diamond a \wedge \Diamond b = 0$, then $a = 0$ or $b = 0$.

It is worth observing that free positive S_4 -algebras are well-connected. This follows immediately from the well-known fact that free S_4 -algebras are well-connected or, equivalently, from the fact that the modal system S_4 has the modal disjunction property.

The results in this section show that certain aspects of finitely subdirectly irreducible and simple algebras are preserved from S_4 -algebras to their positive subreducts. Given a positive modal algebra A , let $\mathcal{M}(A)$ be the modal algebra defined the proof of Theorem 3.8.

Theorem 4.2. *If $A \in \text{PS4}$ is finitely subdirectly irreducible, then so is $\mathcal{M}(A)$.*

Proof. Consider a finitely subdirectly irreducible algebra $A \in \text{PS4}$. The fact that A is a positive subreduct of an S_4 -algebra, together with the correspondence between open filters and congruences typical of modal algebras, easily implies that A is well-connected.

Since A is well-connected, the following sets are, respectively, a proper filter and a proper ideal of A :

$$F := \{a \in A : \Diamond b \leq a \text{ for some } b \in A \setminus \{0\}\}$$

$$I := \{a \in A : a \leq \Box b \text{ for some } b \in A \setminus \{1\}\}.$$

We claim that $F \cap I = \emptyset$. Suppose the contrary in view of a contradiction. Then there is $a \in F \cap I$, i.e. there are $b, c \in A$ such that

$$0 < \Diamond b \leq a \leq \Box c < 1.$$

Consider the embedding $\kappa : A \rightarrow \mathcal{M}(A)$ defined in the proof of Theorem 3.8. Let F and G be respectively the upsets of $\neg\kappa(\Diamond b)$ and $\kappa(\Box c)$ in $\mathcal{M}(A)$. From the fact that $\Diamond b$ and $\Box c$ are respectively fixed points of \Diamond and \Box , it follows that F and G are open filters. Since $\Diamond b \leq \Box c$, we have that $F \cap G = \{1\}$. This means that $\theta_F \cap \theta_G = \text{Id}_{\mathcal{M}(A)}$. Define

$$\phi_F := \{\langle x, y \rangle \in A^2 : \langle \kappa(x), \kappa(y) \rangle \in \theta_F\}$$

$$\phi_G := \{\langle x, y \rangle \in A^2 : \langle \kappa(x), \kappa(y) \rangle \in \theta_G\}.$$

Clearly we have that $\phi_F \cap \phi_G = \text{Id}_A$. Moreover, neither ϕ_F nor ϕ_G are the identity relation, since $\langle \Diamond b, 0 \rangle \in \phi_F$ and $\langle \Box c, 1 \rangle \in \phi_G$. But this contradicts the fact that A is finitely subdirectly irreducible, establishing the claim.

From the claim it follows that $F \cap I = \emptyset$. From the Prime Filter Theorem it follows that there is a prime filter F^* extending F and such that $F^* \cap I = \emptyset$. In particular, we have that for every $a \in A$,

$$(\Box a \in F^* \implies a = 1) \text{ and } (\Diamond a \notin F^* \implies a = 0).$$

This implies that for every $G \in \text{Pr}(A)$,

$$\Box^{-1}F^* \subseteq G \subseteq \Diamond^{-1}F^*, \text{ for every } G \in \text{Pr}(A). \quad (3)$$

Suppose in view of a contradiction that $\mathcal{M}(A)$ is not subdirectly irreducible, i.e. that it is not well-connected. Then there are two elements $X, Y \in \mathcal{M}(A) \setminus \{1\}$ such that $\Box X \vee \Box Y = 1$. Observe that

$$X, Y \in \mathcal{P}(\text{Pr}(A)) \setminus \{\text{Pr}(A)\} \text{ and } \Box X \cup \Box Y = \text{Pr}(A).$$

In particular, we have that $F^* \in \Box X \cup \Box Y$. We can assume w.l.o.g. that $F^* \in \Box X$. From the definition of the operation \Box in $\mathcal{M}(A)$ it follows that for every $G \in \text{Pr}(A)$,

$$\Box^{-1}F^* \subseteq G \subseteq \Diamond^{-1}F^* \implies G \in X.$$

Together with (3), this implies that $X = \text{Pr}(A)$ which is a contradiction. Hence we conclude that $\mathcal{M}(A)$ is finitely subdirectly irreducible. \square

Corollary 4.3. *Consider $A \in \text{PS4}$ finitely subdirectly irreducible. A is well-connected and for every $a \in A \setminus \{0, 1\}$ either $\Box a < a$ or $a < \Diamond a$.*

However the converse of Theorem 4.2 does not hold in general, as shown in the next example. The failure of the converse is due to the fact that the correspondence between open filters and congruences is lost, when we move from S_4 -algebras to their positive subreducts.

Example 4.4. It is natural to wonder whether properties such as *being well-connected* or *being finitely subdirectly irreducible* are preserved or reflected by the passage from a positive S_4 -algebra A to the S_4 -algebra $\mathcal{M}(A)$. It turns out that the situation is as follows:

- (i) If A is finitely subdirectly irreducible, then so is $\mathcal{M}(A)$.
- (ii) If $\mathcal{M}(A)$ is well-connected, then so is A .
- (iii) Even if A is well-connected, $\mathcal{M}(A)$ may fail to be so.
- (iv) Even if $\mathcal{M}(A)$ is finitely subdirectly irreducible, A may fail to be so.

Observe that (i) amounts to Theorem 4.2, while (ii) is clear.

(iii): Observe that in a positive S_4 -algebra we always have that 0 and 1 are fixed points of the modal operations. Consider the positive S_4 -algebra A , whose lattice reduct is the three element chain $0 < a < 1$ and such that $\Box a = \Diamond a = 1$. Clearly A is well-connected. However, $\mathcal{M}(A)$ is the four element modal algebra where the modal operations are interpreted as identity maps. In particular, $\mathcal{M}(A)$ is not well-connected.

(iv): Consider the positive S_4 -algebra A , whose lattice reduct is the five element chain $0 < a < b < c < 1$ and such that $\Box e = 0$ and $\Diamond e = 1$ for every $e \in \{a, b, c\}$. Consider the following equivalence relations, described through their blocks:

$$\theta := \{\{0\}, \{a, b\}, \{c\}, \{1\}\} \text{ and } \phi := \{\{0\}, \{a\}, \{b, c\}, \{1\}\}.$$

Clearly $\theta, \phi \in \text{Con}A$ and $\theta \cap \phi = \text{Id}_A$. Thus the identity relation is not meet-irreducible in $\text{Con}A$ and, therefore, A is not finitely subdirectly irreducible. However, it is not hard to see that $\mathcal{M}(A)$ is a simple S_4 -algebra. \square

The failure of the correspondence between open filters and congruences makes it hard to imagine a concrete description of subdirectly irreducible positive S_4 -algebras.³ Additional difficulties in the description of subdirectly irreducible positive modal algebras arise from the fact that the CEP (and, therefore, also EDPC) fails in PS_4 as shown in Example 4.6. Nevertheless it is easy to obtain a complete description of all simple positive K_4 -algebras. To this end, let B_2 be the unique two-element positive modal algebra such that $\diamond 1 = 0$ and $\square 0 = 1$.

Lemma 4.5. *Let A be a non-trivial member of PK_4 . A is simple if and only if either $A = B_2$ or the following conditions hold:*

(i) *For every $a \in A$:*

$$\square a := \begin{cases} 1 & \text{if } a = 1 \\ 0 & \text{otherwise} \end{cases} \quad \diamond a := \begin{cases} 0 & \text{if } a = 0 \\ 1 & \text{otherwise} \end{cases}.$$

(ii) *For every $a, b \in A$ such that $0 < a < b < 1$, there is $c \in A \setminus \{0, 1\}$ such that*

$$\text{either } (a \leq c \text{ and } b \vee c = 1) \text{ or } (c \leq b \text{ and } a \wedge c = 0).$$

Proof. We begin by proving the “only if” part. Suppose that A is simple and not isomorphic to B_2 . We claim that $\square 0 \neq 1$. To prove this suppose towards a contradiction that $\square 0 = 1$. Then clearly by monotonicity $\square a = 1$ for all $a \in A$. From the fact that $\square 0 = 1$, it follows that $\diamond 1 = 0$. Together with the fact that A is not isomorphic to B_2 , we obtain that there is an element $a \in A$ such that $0 < a < 1$. Then consider the embedding $\kappa: A \rightarrow \mathcal{M}(A)$ defined in the proof of Theorem 3.8. Let F be the upset of $\kappa(a)$ in $\mathcal{M}(A)$. From the fact that $\square a = 1$, it follows that F is an open filter. We have that

$$\langle \kappa(a), 1 \rangle \in \theta_F \text{ and } \langle \kappa(a), 0 \rangle \notin \theta_F.$$

We define $\phi := \{(b, c) \in A^2 : \langle \kappa(b), \kappa(c) \rangle \in \theta_F\}$. Clearly ϕ is a congruence of A , that is neither the identity nor the total relation. Thus $\kappa(A)$ is not simple, which is a contradiction. This establishes our claim.

Now suppose towards a contradiction that there is an element $a \in A \setminus \{1\}$ such that $\square a \neq 0$. Then consider the embedding $\kappa: A \rightarrow \mathcal{M}(A)$. Let F be the principal filter generated by $\kappa(\square a)$ in $\mathcal{M}(A)$. We have that

$$\langle \kappa(\square a), 1 \rangle \in \theta_F \text{ and } \langle \kappa(\square a), 0 \rangle \notin \theta_F.$$

Again we define $\phi := \{(b, c) \in A^2 : \langle \kappa(b), \kappa(c) \rangle \in \theta_F\}$. Clearly ϕ is a congruence of A , that is not the total relation on A , since $\langle \square a, 0 \rangle \notin \phi$. Since

³It is worth remarking that subdirectly irreducible positive modal algebras have been characterized by means of topological properties of their corresponding K^+ -spaces [12]. However, it is not straightforward to apply this characterization to the study of problems such as the classifications of varieties of positive modal algebras.

A is simple, this implies that ϕ is the identity relation on A . In particular, this means that $\Box a = 1$. From our claim it follows that $0 \neq a$. Then consider the upset F of $\kappa(a)$ in $\mathcal{M}(A)$. From the fact that $\Box a = 1$, it follows that F is an open filter. We have that

$$\langle \kappa(a), 0 \rangle \notin \theta_F \text{ and } \langle \kappa(a), 1 \rangle \in \theta_F.$$

We define $\phi := \{ \langle b, c \rangle \in A^2 : \langle \kappa(b), \kappa(c) \rangle \in \theta_F \}$. Clearly ϕ is a congruence of A , that is neither the identity (since $a \neq 1$) nor the total relation. Thus A is not simple, which is a contradiction. We conclude $\Box a = 0$ for all $a \neq 1$. A similar argument shows that $\Diamond a = 1$ for every $a \neq 0$. The only difference from the one described above is that this time one need to rely on the correspondence between the congruences of $\mathcal{M}(A)$ and its ideals closed under \Diamond .

Now, suppose towards a contradiction that there are $a, b \in A$ such that $0 < a < b < 1$ and for which condition (ii) of the statement fails. Consider the congruence θ of the bounded lattice $\langle A, \wedge, \vee, 0, 1 \rangle$ generated by the pair $\langle a, b \rangle$. Clearly θ is not the identity relation. Applying EDPC for distributive lattices as in (1), it is easy to see that $\{0\}$ and $\{1\}$ are blocks of θ . Thus θ is not the total relation. Now we prove that θ is compatible w.r.t. \Box and \Diamond . Consider a pair $\langle c, d \rangle \in \theta$ such that $c \neq d$. From the fact that $\{0\}$ and $\{1\}$ are blocks of θ , it follows that $0 < c, d < 1$. As we showed, this means that $\Box c = \Box d = 0$ and $\Diamond c = \Diamond d = 1$. We conclude that θ is a congruence of A , which contradicts the fact that A is simple. This establishes that condition (ii) in the statement holds.

Then we turn to prove the “if” part. Observe that \mathbf{B}_2 is simple on cardinality grounds. Then suppose that A satisfies conditions (i) and (ii) in the statement. Suppose towards a contradiction that A is not simple. Then there are two different elements $a, b \in A$ such that $\text{Cg}(a, b)$ is not the total relation. We can assume w.l.o.g. that $a < b$. Observe that $0 < a$. Suppose towards a contradiction that $a = 0$. Then $b < 1$, since $\text{Cg}(a, b)$ is not the total relation. From condition (i) we know that $\Diamond a = 0$ and $\Diamond b = 1$. But this implies that $\text{Cg}(a, b)$ is the total relation, which is false. This establishes that $0 < a$. A similar argument shows that $b < 1$. Hence we have that $0 < a < b < 1$ and we can apply condition (ii) in the statement. This condition, together with EDPC for distributive lattices as in (1), implies that there is $c \in A \setminus \{0, 1\}$ such that either the pair $\langle c, 1 \rangle$ or the pair $\langle c, 0 \rangle$ belongs to $\text{Cg}(a, b)$. Together with the fact that $\Diamond c = 1$ and $\Box c = 0$, this implies that $\langle 0, 1 \rangle \in \text{Cg}(a, b)$. But this means that $\text{Cg}(a, b)$ is the total congruence, which is a contradiction. \boxtimes

As we promised, the next example shows that PS4 does not have the CEP and, therefore, it does not have EDPC either. This contrasts with the well-known fact that the variety of S4-algebras has EDPC.

Example 4.6. Consider any Boolean lattice $\langle A, \wedge, \vee, 0, 1 \rangle$ of at least 8 elements. Then equip it with modal operations \Box and \Diamond defined as in

condition (i) of Lemma 4.5. Let A be the resulting positive S_4 -algebra. Consider any chain $0 < a < b < 1$ in $\langle A, \leq \rangle$. Observe that setting $c := a \vee \neg b$, where $\neg b$ is the Boolean complement of b , we have that

$$b \vee c = 1 \text{ and } a \leq c.$$

Hence A satisfies condition (ii) of Lemma 4.5. We conclude that A is a simple algebra. Now consider any chain $0 < a < b < 1$ in $\langle A, \leq \rangle$. Observe that it is the universe of a subalgebra B of A . It is easy to see that B is not simple. Therefore A is a simple algebra with a non-simple and non-trivial subalgebra. We conclude that PS4 does not have the CEP. \square

5. FREE ONE-GENERATED POSITIVE S_4 -ALGEBRA

Observe that the free one-generated positive K_4 -algebra is infinite. This can be easily seen by observing that it contains the infinite ascending chain

$$\llbracket \Box x \rrbracket < \llbracket \Box^2 x \rrbracket < \llbracket \Box^3 x \rrbracket < \dots$$

In this section we will prove that the situation changes for positive S_4 -algebras, whose free one-generated algebra turns out to be finite. This fact contrasts with the full-signature case, since it is well known that the free one-generated S_4 -algebra is infinite, see for instance [56].

For the sake of simplicity, let us introduce a way of describing pictorially positive S_4 -algebras. Let A be a positive S_4 -algebra. Then the structure of A is uniquely determined by its Hasse diagram and the fixed points of the modal operations. This is because for every $a \in A$, the element $\Box a$ (resp. $\Diamond a$) is the greatest fixed point of \Box below a (resp. smallest fixed point of \Diamond above a). Thus a way of describing the structure of $A \in \text{PS4}$ is to depict its Hasse diagram and to mark with a \Box (resp. with a \Diamond) the fixed points of \Box (resp. of \Diamond). We omit these marks for 0 and 1, which are always fixed points of the modal operations, since A is a positive modal algebra. An example of this way of representing positive S_4 -algebras is offered in Figure 1.

Theorem 5.1. *The algebra A depicted in Figure 1 is the free one-generated positive S_4 -algebra.*

Proof. Consider the terms

$$\Sigma := \{x, \Box x, \Diamond \Box x, \Box \Diamond \Box x, \Diamond x, \Box \Diamond x, \Box \Diamond \Box x\}. \quad (4)$$

We will make use of the following easy observation:

Fact 5.2. *For every positive S_4 -algebra B and $b \in B$, the elements $\{\varphi^B(b) : \varphi \in \Sigma\} \subseteq B$ form the following subposet of $\langle B, \leq \rangle$, where the lines indicate only the order relation and must not be interpreted as referring to any description of meets*

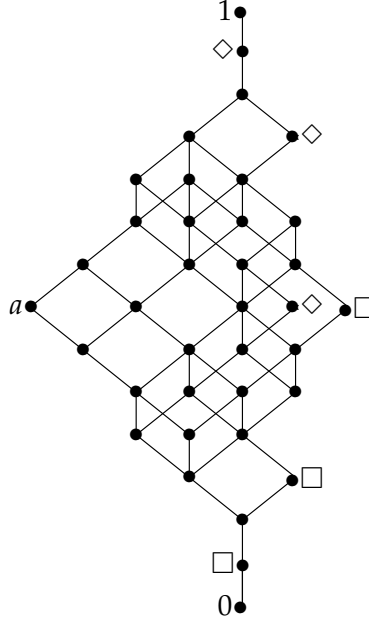
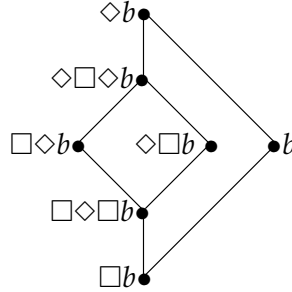

FIGURE 1. The free one-generated positive S_4 -algebra

and joins, and whose elements are not necessarily different one from the other:



Now, let A be the algebra depicted in Figure 1. It is an easy exercise to check that the algebra A is in fact a positive S_4 -algebra. Moreover, the bounded lattice reduct of A is obtained as follows. First we consider the free 7-generated bounded distributive lattice C , whose generators are the terms in Σ . Second we form the quotient of C under the congruence generated by following the set

$$\Gamma := \{ \langle \varphi, \psi \rangle \in \Sigma^2 : \varphi(b) \leq \psi(b) \text{ in the above diagram} \}.$$

The algebra $C/\text{Cg}(\Gamma)$ obtained in this way is exactly the bounded lattice reduct of A . This can be checked mechanically, e.g. using the Universal Algebra Calculator [24]. In particular, for every element $c \in A$ there is a

bounded lattice term $t_c(y_1, \dots, y_7)$ such that

$$c = t_c^A(a, \Box a, \Diamond \Box a, \Box \Diamond \Box a, \Diamond a, \Box \Diamond a, \Box \Diamond \Box a).$$

We can assume w.l.o.g. that

$$t_0 = 0, t_1 = 1 \text{ and } t_a = y_1, t_{\Box a} = y_2, \dots, t_{\Box \Diamond \Box a} = y_7.$$

In order to prove that A is the free one-generated positive S4-algebra with free generator a , it will be enough to show that A enjoys the following universal property: for every $B \in \text{PS4}$ and $b \in B$, there is a unique homomorphism $f: A \rightarrow B$ such that $f(a) = b$. The uniqueness of the homomorphism f is ensured by the fact that A is generated by a . Then it only remains to prove its existence. To this end, consider the map $f: A \rightarrow B$ defined by the following rule:

$$f(c) := t_c^B(b, \Box b, \Diamond \Box b, \Box \Diamond \Box b, \Diamond b, \Box \Diamond b, \Box \Diamond \Box b).$$

To prove that f is a homomorphism of bounded lattices, we reason as follows. Clearly f preserves 0 and 1, since $t_0 = 0$ and $t_1 = 0$. Moreover, the lattice reduct of A is freely-generated by $a, \Box a, \Diamond \Box a, \Box \Diamond \Box a, \Diamond a, \Box \Diamond a, \Box \Diamond \Box a$ w.r.t. to the inequalities in Γ , together with Fact 5.2, implies that f is a lattice homomorphism as well.

It only remains to prove that f preserves the modal operations. We will detail only the fact that f preserves \Box . Consider the following partition θ of A :

$$\{0\}, [\Box a, a], [\Box \Diamond a, \Diamond a], [\Box \Diamond \Box a, a \vee \Diamond \Box a], \{1\}.$$

Observe that if two elements $c, d \in A$ belong to the same block of θ , then $\Box^A c = \Box^A d$. Since f preserves 0 and 1, we have that

$$f(\Box 0) = f(0) = 0 = \Box 0 \text{ and } f(\Box 1) = f(1) = 1 = \Box 1.$$

Then, suppose that $c \in [\Box a, a] \cup [\Box \Diamond a, \Diamond a] \cup [\Box \Diamond \Box a, a \vee \Diamond \Box a]$. We have that following cases:

1. $c \in [\Box \Diamond \Box a, a \vee \Diamond \Box a]$.
2. $c \in [\Box a, a]$.
3. $c \in [\Box \Diamond a, \Diamond a]$.

1. Observe that

$$\text{PS4} \models \Box(x \vee \Diamond \Box x) \leq \Box x \vee \Diamond \Box x = \Diamond \Box x.$$

Together with the monotonicity of \Box , this implies that

$$\Box(x \vee \Diamond \Box x) = \Box \Box(x \vee \Diamond \Box x) \leq \Box \Diamond \Box x.$$

Finally, from the fact that $\Diamond \Box x \leq x \vee \Diamond \Box x$, it follows that $\Box \Diamond \Box x \leq \Box(x \vee \Diamond \Box x)$. We conclude that

$$\text{PS4} \models \Box(x \vee \Diamond \Box x) \approx \Box \Diamond \Box x. \quad (5)$$

Since $c \in [\Box \Diamond \Box a, a \vee \Diamond \Box a]$ and f is order preserving, we have that:

$$\Box \Diamond \Box b = f(\Box \Diamond \Box a) \leq f(c) \leq f(a \vee \Diamond \Box a) = b \vee \Diamond \Box b.$$

Together with (5), this implies that $\Box f(c) = \Box \diamond \Box b$. Moreover, we have that

$$f(\Box c) = f(\Box \diamond \Box a) = \Box \diamond \Box b.$$

Hence we conclude that $\Box f(c) = \Box \diamond \Box b = f(\Box c)$.

Cases 2 and 3 are almost straightforward. For this reason we detail only case 2. Consider $c \in [\Box a, a]$. Since f is monotone, we have that $\Box b = f(\Box a) \leq f(c) \leq f(a) = b$. In particular, this implies that $\Box f(c) = \Box b$. Moreover, we have that $f(\Box c) = f(\Box a) = \Box b$. Hence we conclude that $\Box f(c) = \Box b = f(\Box c)$.

We conclude that f preserves \Box . A similar argument shows that f preserves \diamond as well. Hence $f: \mathbf{A} \rightarrow \mathbf{B}$ is a homomorphism, as desired. \square

It is natural to wonder whether the free two-generated positive S_4 -algebra is finite as well. It turns out that this is not the case, as witnessed by a small modification of the example in [6, Figure 4]:

Lemma 5.3. *The free two-generated positive S_4 -algebra is infinite.*

Proof. It will be enough to show that there exists an infinite two-generated positive S_4 -algebra. To this end, consider the set of natural numbers ω equipped with the relation \geq . Clearly \geq is a reflexive and transitive relation on ω . This implies that the structure

$$\mathbf{A} = \langle \mathcal{P}(\omega), \cap, \cup, \Box_{\geq}, \diamond_{\geq}, \emptyset, \omega \rangle$$

is indeed a positive S_4 -algebra.

We define recursively a formula $\varphi_n(x, y)$, for every $n \in \omega$, as follows:

$$\varphi_0 := \Box x \text{ and } \varphi_{m+1} = \begin{cases} \Box(x \vee \varphi_m) & \text{if } m \text{ is odd} \\ \Box(y \vee \varphi_m) & \text{if } m \text{ is even.} \end{cases}$$

Then consider the following elements of \mathbf{A} :

$$c := \{2n : n \in \omega\} \text{ and } d := \{2n + 1 : n \in \omega\}.$$

We have that for every $n \in \omega$,

$$\varphi_n^{\mathbf{A}}(c, d) = \{m \in \omega : m \leq n\}.$$

Thus if $n \neq m$, then $\varphi_n^{\mathbf{A}}(c, d) \neq \varphi_m^{\mathbf{A}}(c, d)$. Hence the subalgebra \mathbf{B} of \mathbf{A} , generated by the two-element set $\{c, d\}$, is infinite. \square

A variety \mathbf{K} is *locally finite* if its finitely generated members are finite. Equivalently \mathbf{K} is locally finite, when its finitely generated free algebras are finite.

Corollary 5.4. *PS4 is not locally finite.*

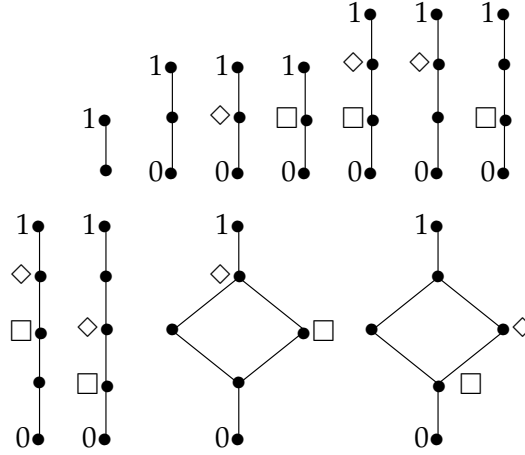

FIGURE 2. One-generated subdirectly irreducible algebras

6. BOTTOM OF THE SUBVARIETY LATTICE

In this section we will use the characterization of the free one-generated positive S_4 -algebra, to describe the bottom of the lattice of subvarieties of PS_4 . To this end, observe that the one-generated subdirectly irreducible positive S_4 -algebras coincide with the subdirectly irreducible homomorphic images of $Fm_{PS_4}(x)$. Since $Fm_{PS_4}(x)$ is described in Figure 1, we can find these algebras by inspection. As a result we obtain that there are exactly 11 one-generated subdirectly irreducible positive S_4 -algebras, which are depicted in Figure 2. Reading from left to right, we will denote them respectively by

$$C_2, D_3, C_3^a, C_3^b, D_4, C_4^a, C_4^b, C_5^a, C_5^b, C_6^a \text{ and } C_6^b.$$

The following observation is immediate:

Lemma 6.1. $\mathbb{V}(C_2)$ is the unique minimal variety of positive S_4 -algebra. This variety is term-equivalent to the one of bounded distributive lattices.

Proof. Just observe that C_2 embeds into every non-trivial positive S_4 -algebra, and that C_2 is term-equivalent to the two-element bounded distributive lattice. \square

The next result characterizes the covers of $\mathbb{V}(C_2)$ in the lattice of subvarieties of PS_4 .

Theorem 6.2. $\mathbb{V}(D_3)$, $\mathbb{V}(C_3^a)$, $\mathbb{V}(C_3^b)$ and $\mathbb{V}(D_4)$ are the unique covers of $\mathbb{V}(C_2)$ in the lattice of subvarieties of PS_4 . Moreover, if K is a subvariety of PS_4 such that $\mathbb{V}(C_2) \subsetneq K$, then K includes one of these varieties.

Proof. Applying Jónsson's lemma to the algebras of Figure 2, it is easy to see that the unique covers of $\mathbb{V}(C_2)$ generated by a one-generated subdirectly

irreducible positive S_4 -algebra are $\mathbb{V}(D_3)$, $\mathbb{V}(C_3^a)$, $\mathbb{V}(C_3^b)$ and $\mathbb{V}(D_4)$. Now, consider any subvariety K of PS_4 such that $\mathbb{V}(C_2) \subsetneq K$. We claim that the equational theory in one variable of K differs from the one of C_2 . Suppose the contrary towards a contradiction. Then we have that

$$K \models x \approx \square x \approx \diamond x.$$

This implies that K is term-equivalent to the variety of bounded distributive lattices. Keeping this in mind, it is easy to see that $K = \mathbb{V}(C_2)$, which contradicts the fact that K properly extends $\mathbb{V}(C_2)$. This establishes the claim. Hence there is a one-generated subdirectly irreducible algebra $A \not\cong C_2$ such that $A \in K$. Now, we know that A is one of the algebras in Figure 2. Keeping this in mind, it is easy to see that $\mathbb{V}(A) \cap \{D_3, C_3^a, C_3^b, D_4\} \neq \emptyset$. Thus we conclude that K contains one of the following varieties: $\mathbb{V}(D_3)$, $\mathbb{V}(C_3^a)$, $\mathbb{V}(C_3^b)$ and $\mathbb{V}(D_4)$. \square

As it will become clear later on (Theorem 9.6), the variety $\mathbb{V}(D_4)$ is the cornerstone of structural completeness in varieties of positive K_4 -algebras. For this reason, we will devote to it some more attention. In particular, we will prove that $\mathbb{V}(D_4)$ is the variety of positive S_4 -algebras axiomatized by the following equations:

$$\square \diamond x \approx \square x \text{ and } \diamond \square x = \diamond x. \quad (6)$$

The proof will go through a series of lemmas.

Lemma 6.3. *Consider $A \in PS_4$ which satisfies (6). The operations $\square, \diamond: A \rightarrow A$ are bounded lattice endomorphisms. Moreover, their kernels coincide and are congruences of A .*

Proof. We check this for \square . It is clear that \square preserve $0, 1$ and \wedge . Then consider $a, b \in A$. We have that

$$\begin{aligned} \square(a \vee b) &= \square \diamond(a \vee b) = \square(\diamond a \vee \diamond b) = \square(\diamond \square a \vee \diamond \square b) \\ &= \square \diamond(\square a \vee \square b) = \square(\square a \vee \square b) = \square a \vee \square b. \end{aligned}$$

Thus we conclude that \square preserves \vee and, therefore, that it is a bounded lattice endomorphism. A dual argument yields the same result for \diamond .

Now observe that for every $a, b \in A$ we have that if $\square a = \square b$, then $\diamond a = \diamond \square a = \diamond \square b = \diamond b$. Thus the kernel of \square is included into the kernel of \diamond . An analogous argument shows the other inclusion. Then let θ be the kernel of \square and \diamond . It is clear that θ preserves \square and \wedge , since it is the kernel of \square . Moreover θ preserves \diamond and \vee , since it is the kernel of \diamond . \square

Corollary 6.4. *Consider $A \in PS_4$ which satisfies (6) and $a, b \in A$. If $\square a = \square b$, then $\text{Cg}(a, b)$ coincides with the lattice-congruence generated by the pair $\langle a, b \rangle$.*

Proof. Let θ be the kernel of \square . By Lemma 6.3 we know that $\theta \in \text{Con}A$. In particular, this implies that $\text{Cg}(a, b) \subseteq \theta$. Let ϕ be the lattice-congruence generated by $\langle a, b \rangle$. We have to prove that $\phi = \text{Cg}(a, b)$. It is clear that $\phi \subseteq \text{Cg}(a, b)$. In order to check the other inclusion, it will be enough to

show that ϕ preserves the modal operations. To this end consider $\langle c, d \rangle \in \phi$. Since $\phi \subseteq \text{Cg}(a, b) \subseteq \theta$, we know that $\Box c = \Box d$ and $\Diamond c = \Diamond d$. Thus we conclude that $\langle \Box c, \Box d \rangle = \langle \Box c, \Box c \rangle \in \phi$ and, analogously, $\langle \Diamond c, \Diamond d \rangle \in \phi$. \boxtimes

Lemma 6.5. *Consider $A \in \text{PS4}$ subdirectly irreducible with monolith $\text{Cg}(a, b)$ with $a < b$. If A satisfies (6) then:*

1. *For every $c \in A$: if $b \leq c < 1$, then $c = \Diamond c$.*
2. *For every $c \in A$: if $0 < c \leq a$, then $c = \Box c$.*

Proof. We prove only point 1. Suppose towards a contradiction that $c < \Diamond c$. We know that $\Box c = \Box \Diamond c$. By Corollary 6.4 we know that $\text{Cg}(c, \Diamond c)$ coincides with the lattice-congruence generated by $\langle c, \Diamond c \rangle$. By (1) this means that

$$\langle x, y \rangle \in \text{Cg}(c, \Diamond c) \iff (x \wedge c = y \wedge c \text{ and } x \vee \Diamond c = y \vee \Diamond c).$$

But this implies that $\langle a, b \rangle \notin \text{Cg}(c, \Diamond c)$ and contradicts the fact that $\text{Cg}(a, b)$ is the monolith of A . We conclude that $\Diamond c = c$. \boxtimes

In order to prove that $\mathbb{V}(D_4)$ is axiomatized by (6), we need a last technical lemma.

Lemma 6.6. *Let $A \in \text{PS4}$ be subdirectly irreducible satisfying (6), and $a \in A$.*

1. *If $\Box a < a$, then $\text{Cg}(\Box a, a)$ is the monolith of A .*
2. *If $a < \Diamond a$, then $\text{Cg}(a, \Diamond a)$ is the monolith of A .*

Proof. Let $\text{Cg}(b, c)$ be the monolith of A with $b < c$. We will prove only point 1. Consider $a \in A$ such that $\Box a < a$. Applying several times point 2 of Lemma 6.5, we obtain that

$$a \wedge b = \Box(a \wedge b) = \Box a \wedge \Box b = b \wedge \Box a.$$

Applying several times point 1 of Lemma 6.5, we obtain that

$$a \vee c = \Diamond(a \vee c) = \Diamond c \vee \Diamond a = \Diamond c \vee \Diamond \Box a = \Diamond(c \vee \Box a) = c \vee \Box a.$$

The two displays show that the pair $\langle \Box a, a \rangle$ belongs to the lattice-congruence generated by $\langle b, c \rangle$. In particular, this implies that $\langle \Box a, a \rangle \in \text{Cg}(b, c)$. Since $a \neq \Box a$ and $\text{Cg}(b, c)$ is the monolith of A , we conclude that $\text{Cg}(\Box a, a) = \text{Cg}(b, c)$. \boxtimes

We are finally ready to prove the desired result:

Theorem 6.7. *$\mathbb{V}(D_4)$ is the variety of positive S_4 -algebras axiomatized by the equations (6).*

Proof. Consider a subdirectly irreducible positive S_4 -algebra A , which satisfies (6). Moreover, suppose that A is not isomorphic to C_2 . Our goal is to show that $A \cong C_4$. First observe that for every $a \in A \setminus \{0, 1\}$

$$\text{either } (\Box a \neq a \text{ and } a = \Diamond a) \text{ or } (\Box a = a \text{ and } a \neq \Diamond a). \quad (7)$$

To prove this, consider $a \in A \setminus \{0, 1\}$. By Corollary 4.3 we know that either $\Box a < a$ or $a < \Diamond a$. We detail the case where $\Box a < a$, since the

other one is similar. We want to prove that $a = \diamond a$. Suppose towards a contradiction that $a < \diamond a$. By Corollary 6.4 we know that $\text{Cg}(\Box a, a)$ is the lattice congruence generated by the pair $\langle \Box a, a \rangle$. In particular, this implies that $\langle a, \diamond a \rangle \notin \text{Cg}(\Box a, a)$. But this contradicts the fact that $\text{Cg}(a, \diamond a)$ is the monolith of A by point 2 of Lemma 6.6. This establishes (7).

Now consider the equivalence relation, defined through its blocks:

$$\theta := \{\{0\}, \{\Box a : a \neq 0, 1\}, \{\diamond a : a \neq 0, 1\}, \{1\}\}.$$

From (7) it follows that the blocks of θ are pair-wise disjoint. Moreover, by (7) we know that every element of A belongs to one of the blocks. Thus θ is a well defined equivalence relation. We claim that θ is a congruence of A . The fact that θ preserves the modal operations is easy to prove. We will sketch the proof of the preservation of \Box . Consider two *different* elements a, b in the same block of θ . We have two cases: either a and b are both fixed points of \Box or they are both fixed points of \diamond . If a and b are fixed points of \Box , then we are done. Then consider the case where a and b are fixed points of \diamond , i.e.,

$$a, b \in \{\diamond c : c \neq 0, 1\}.$$

In particular, this means that $a, b \neq 0, 1$. Thus we conclude that $\Box a, \Box b \in \{\Box c : c \neq 0, 1\}$. We conclude that θ preserves \Box . A similar argument shows that θ preserves \diamond .

Hence it only remains to prove that θ preserves the lattice operations. We detail the proof of the fact that θ preserves \wedge . Consider $a, b, c, d \in A$ such that $\langle a, b \rangle, \langle c, d \rangle \in \theta$. Looking at the definition of θ it is easy to see that the only non-trivial cases are the following:

1. $a, b, c, d \in \{\Box e : e \neq 0, 1\}$.
 2. $a, b, c, d \in \{\diamond e : e \neq 0, 1\}$.
 3. $a, b \in \{\Box e : e \neq 0, 1\}$ and $c, d \in \{\diamond e : e \neq 0, 1\}$.
1. Observe that $\Box(a \wedge c) = \Box a \wedge \Box c = a \wedge c$ and, similarly, $\Box(b \wedge d) = b \wedge d$. Therefore, in order to prove that $\langle a \wedge c, b \wedge d \rangle \in \theta$, it will be enough to show that $a \wedge c, b \wedge d \neq 0, 1$. We already know that a, b, c, d are different from 0 and 1. Thus $a \wedge c, b \wedge d \neq 1$. Suppose towards a contradiction that either $a \wedge c = 0$ or $b \wedge d = 0$. We assume w.l.o.g. that $a \wedge c = 0$. Applying the fact that \diamond commutes with \wedge by Lemma 6.3, we obtain that

$$\diamond a \wedge \diamond c = \diamond(a \wedge c) = \diamond 0 = 0.$$

Keeping in mind that $a, c \neq 0$, this contradicts the fact that A is well-connected by Corollary 4.3. Thus we conclude that $a \wedge c \neq 0$ (and $b \wedge d \neq 0$). This implies that $\langle a \wedge c, b \wedge d \rangle \in \theta$.

A similar argument establishes case 2. Then we consider case 3. First observe that $a \wedge c$ is a fixed point of \Box . Suppose the contrary towards a contradiction. By Lemma 6.6 we know that $\text{Cg}(\Box(a \wedge c), a \wedge c)$ is the monolith of A . Moreover, $\text{Cg}(\Box(a \wedge c), a \wedge c)$ is the lattice congruence generated by the pair $\langle \Box(a \wedge c), a \wedge c \rangle$ by Corollary 6.4. Together with the fact that $a < \diamond a$, this implies using (1) that $\langle a, \diamond a \rangle \notin \text{Cg}(\Box(a \wedge c), a \wedge c)$.

But this contradicts the fact that $\text{Cg}(a, \diamond a)$ is the monolith of A by Lemma 6.6. Thus we conclude that $a \wedge c$ is a fixed point of \square . A similar argument shows that the same holds for $b \wedge d$. In order to prove that $\langle a \wedge c, b \wedge d \rangle \in \theta$ it will be enough to show that $a \wedge c, b \wedge d \neq 0, 1$. We already know that the elements a, b, c, d are different from 0 and 1. Thus $a \wedge c, b \wedge d \neq 1$. Suppose towards a contradiction that $a \wedge c = 0$ or $b \wedge d = 0$. Assume w.l.o.g. that $a \wedge c = 0$. Keeping in mind that \diamond commutes with \wedge by Lemma 6.3, we obtain that

$$\diamond a \wedge \diamond c = \diamond(a \wedge c) = \diamond 0 = 0.$$

Together with the fact that $a, c \neq 0$, this contradicts the fact that A is well-connected by Corollary 4.3. Hence we conclude that $\langle a \wedge c, b \wedge d \rangle \in \theta$. This establishes our claim.

Recall that the four blocks of θ are pair-wise distinct. It is not difficult to see that $A/\theta \cong D_4$. Therefore, in case $\theta = \text{Id}_A$, we are done. Suppose towards a contradiction that $\theta \neq \text{Id}_A$. By Lemma 6.3 we know that the kernel ϕ of \square coincides with the kernel of \diamond and is a congruence of A . Since A is subdirectly irreducible and not isomorphic to C_2 , we know that either \square^A or \diamond^A is not the identity relation. This implies that $\phi \neq \text{Id}_A$. We will show that $\theta \cap \phi = \text{Id}_A$, contradicting the fact that the identity relation is meet-irreducible in $\text{Con}A$. Consider two different elements $a, b \in A$ such that $\langle a, b \rangle \in \phi$. This means that $\square a = \square b$ and $\diamond a = \diamond b$. Together with the fact that $a \neq b$, this implies that $a, b \neq 0, 1$. By (7) we have two cases: either $\square a = a$ or $a = \diamond a$. We detail the case where $\square a = a$. We have that $b \neq a = \square a = \square b$. By (7) this means that $b = \diamond b$. Thus a and b belongs to two different blocks of θ , that is, $\langle a, b \rangle \notin \theta$. The case where $a = \diamond a$ is handled similarly. Hence we obtain that $\phi \cap \theta = \text{Id}_A$, contradicting the fact that A is subdirectly irreducible. We conclude that $A \cong D_4$.

We have shown that C_2 and D_4 are the unique subdirectly irreducible members of the variety of positive S_4 -algebras axiomatized by (6). We conclude that (6) axiomatizes $\mathbb{V}(D_4)$. \square

7. SOME SPLITTINGS

Let K be a variety. A subdirectly irreducible algebra $A \in K$ is a *splitting algebra* in K if there is a largest subvariety of K excluding A . In this section we will prove some basic results on splitting algebras that will be useful in the sequel. The following lemma is taken from [40] (see also [18]):

Lemma 7.1 (McKenzie). *If a congruence distributive variety is generated by its finite members, then its splitting algebras are finite.*

The well-known fact that the variety of K_4 -algebras is generated by its finite members, together with the fact that PKA is the class of subreducts of K_4 -algebras (Theorem 3.8), implies that PKA is generated by its finite members. Then its splitting algebras are finite by Lemma 7.1. On the other hand, we don't know which finite subdirectly irreducible algebras

are splitting in PKA. A similar argument shows that splitting algebras in PS4 are finite. However, not necessarily all finite subdirectly positive S4-algebras are splitting in PS4.

Lemma 7.2.

1. The largest subvariety of PS4 excluding C_3^a is axiomatized by $\diamond\Box\diamond x \approx \diamond x$.
2. The largest subvariety of PS4 excluding C_3^b is axiomatized by $\Box\diamond\Box x \approx \Box x$.

Proof. We will detail only the proof of 1, since the proof of 2 is similar. Let K be the subvariety of PS4 axiomatized by $\diamond\Box\diamond x \approx \diamond x$. Observe that $C_3^a \notin K$. Then suppose towards a contradiction that there is a variety W such that $C_3^a \notin W$ and $W \not\subseteq K$. This means that $W \not\models \diamond\Box\diamond x \approx \diamond x$. Then there is a one-generated subdirectly irreducible algebra $A \in W$ such that $A \not\models \diamond\Box\diamond x \approx \diamond x$. Taking a look at Figure 2 one sees that either $A = C_3^a$ or $A = C_4^a$. In both cases $C_3^a \in \mathbb{H}(A) \subseteq K$, which is false. \square

We conclude this section by showing that D_3 is a splitting algebra in PKA (and not only in PS4).

Lemma 7.3. D_3 is a splitting algebras in PK4 and the largest subvariety of PK4 excluding D_3 is axiomatized by $\diamond x \wedge \Box\diamond x \leq x \vee \Box x \vee \diamond\Box x$.

Proof. It is clear that a variety of positive K4-algebras satisfying $\diamond x \wedge \Box\diamond x \leq x \vee \Box x \vee \diamond\Box x$ excludes D_3 . To prove the converse we reason towards a contradiction. Suppose that there is a variety of K4-algebras K , which excludes D_3 in which the equation $\diamond x \wedge \Box\diamond x \leq x \vee \Box x \vee \diamond\Box x$ fails. Then there is an algebra $A \in K$ and $a \in A$ such that $\diamond a \wedge \Box\diamond a \not\leq a \vee \Box a \vee \diamond\Box a$. Consider the embedding $\kappa: A \rightarrow \mathcal{M}(A)$ defined in the proof of Theorem 3.8. Let θ be the congruence of $\mathcal{M}(A)$ generated by $\langle \Box\kappa(a), 0 \rangle$ and $\langle \diamond\kappa(a), 1 \rangle$.

We claim that $\langle \kappa(a), 1 \rangle \in \theta$. Suppose the contrary towards a contradiction. Then observe that also $\langle \kappa(a), 0 \rangle \notin \theta$, since

$$\diamond\kappa(a) \equiv_{\theta} 1 \not\equiv_{\theta} 0 = \diamond 0.$$

Then let $\phi := \{ \langle b, c \rangle \in A^2 : \langle \kappa(b), \kappa(c) \rangle \in \theta \}$. We have that the subalgebra of A/ϕ generated by a/ϕ is isomorphic to D_3 . But this contradicts the fact that K excludes D_3 , thus establishing the claim.

Our claim, together with (2) implies that

$$(\Box\kappa(a) \leftrightarrow 0) \wedge \Box(\Box\kappa(a) \leftrightarrow 0) \wedge (\diamond\kappa(a) \leftrightarrow 1) \wedge \Box(\diamond\kappa(a) \leftrightarrow 1) \subseteq \kappa(a) \leftrightarrow 1.$$

It is easy to see that this can be reduced to the following expression:

$$\neg\Box\kappa(a) \cap \neg\diamond\Box\kappa(a) \cap \diamond\kappa(a) \cap \Box\diamond\kappa(a) \subseteq \kappa(a). \quad (8)$$

Recall that $\diamond a \wedge \Box\diamond a \not\leq a \vee \Box a \vee \diamond\Box a$ and, therefore, that

$$\diamond\kappa(a) \cap \Box\diamond\kappa(a) \not\subseteq \kappa(a) \cup \Box\kappa(a) \cup \diamond\Box\kappa(a).$$

By the Prime Filter Theorem, there is an ultrafilter $F \in \text{Pr}(\mathcal{M}(A))$ such that $\diamond\kappa(a) \cap \Box\diamond\kappa(a) \in F$ and $\kappa(a), \Box\kappa(a), \diamond\Box\kappa(a) \notin F$. Since F is an ultrafilter, this contradicts (8). \square

8. VARIETIES OF HEIGHT ≤ 4

In this section we characterize all varieties of positive S_4 -algebras that have height ≤ 4 in the lattice of subvarieties of PS_4 . We begin by finding the covers of $\mathbb{V}(D_3)$, $\mathbb{V}(C_3^a)$, $\mathbb{V}(C_3^b)$ and $\mathbb{V}(D_4)$ in the lattice of subvarieties of PS_4 .

Lemma 8.1. $\mathbb{V}(D_3, D_4)$, $\mathbb{V}(C_3^a, D_4)$ and $\mathbb{V}(C_3^b, D_4)$ are the unique covers of $\mathbb{V}(D_4)$ in the lattice of subvarieties of PS_4 . Moreover, every variety K of positive S_4 -algebras such that $\mathbb{V}(D_4) \subsetneq K$ contains one of these three covers.

Proof. By Jónsson's lemma we obtain that $\mathbb{V}(D_3, D_4)$, $\mathbb{V}(C_3^a, D_4)$ and $\mathbb{V}(C_3^b, D_4)$ are covers of $\mathbb{V}(D_4)$. Suppose towards a contradiction that there is a variety K of positive S_4 -algebras such that $\mathbb{V}(D_4) \subsetneq K$, which does not contain any of the varieties $\mathbb{V}(D_3, D_4)$, $\mathbb{V}(C_3^a, D_4)$ and $\mathbb{V}(C_3^b, D_4)$. Then clearly $D_3, C_3^a, C_3^b \notin K$. By Lemmas 7.2 and 7.3 we know that K satisfies the following equations:

$$\diamond \square \diamond x \approx \diamond x \quad (9)$$

$$\square \diamond \square x \approx \square x \quad (10)$$

$$\diamond x \wedge \square \diamond x \leq x \vee \square x \vee \diamond \square x \quad (11)$$

Observe that in PS_4 the inequality (11) can be simplified as follows:

$$\square \diamond x \leq x \vee \diamond \square x. \quad (12)$$

It is easy to see that $PS_4 \models \square(x \vee \diamond \square x) \approx \square \diamond \square x$. Together with (12), this implies that

$$K \models \square \diamond x \approx \square(\square \diamond x) \leq \square(x \vee \diamond \square x) \approx \square \diamond \square x.$$

Together with (10) this implies that $K \models \square \diamond x \leq \square x$. Since $PS_4 \models \square x \leq \square \diamond x$, we conclude that $K \models \square \diamond x \approx \square x$. A similar argument shows that $K \models \diamond \square x \approx \diamond x$. Hence K satisfies the equations (6). By Theorem 6.7 we conclude that $K \subseteq \mathbb{V}(D_4)$. This contradicts the fact that $\mathbb{V}(D_4) \subsetneq K$. \square

In order to describe the covers of $\mathbb{V}(D_3)$, $\mathbb{V}(C_3^a)$ and $\mathbb{V}(C_3^b)$ we need to introduce the new positive S_4 -algebras depicted in Figure 3. Reading from left to right, we denote them by A_4 , D_5^a , D_5^b and B_4 . The key observation to understand the covers of $\mathbb{V}(D_3)$ is the following:

Lemma 8.2. Let K be a variety of positive S_4 -algebras, whose equational theory in one variable coincides with the one of $\mathbb{V}(D_3)$. If $A \in K_{si} \setminus \{C_2, D_3\}$, then

$$\mathbb{S}(A) \cap \{A_4, B_4\} \neq \emptyset.$$

Proof. Consider $A \in K_{si} \setminus \{C_2, D_3\}$. Observe that

$$\square a = 0 \text{ and } \diamond a = 1 \text{ for every } a \in A \setminus \{0, 1\}. \quad (13)$$

To prove this consider $a \in A \setminus \{0, 1\}$. Observe that $D_3 \models \square x \approx \diamond \square x$. Since K and D_3 have the same equational theory in one variable, we conclude that $\square a$ is a fixed point of \diamond . Thus $\square a$ is a fixed point of both modal operations.

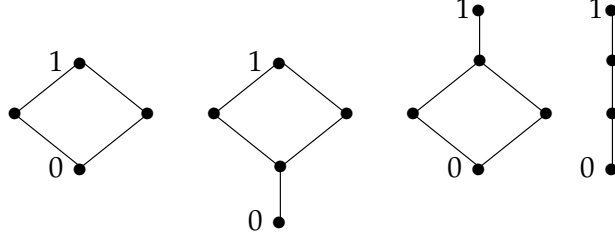
FIGURE 3. Some subdirectly irreducible positive S_4 -algebras

By Corollary 4.3 we conclude that $\Box a \in \{0, 1\}$. Since $a < 1$, we conclude that $\Box a = 0$. A similar argument shows that $\Diamond a = 1$. This establishes (13).

We have three cases: either 1 is not join-prime, or 0 is not meet-prime or none of the previous ones. First we consider the case where 1 is not join-prime. Then there are $a, b < 1$ such that $a \vee b = 1$. From (13) it follows that the elements $\{0, a \wedge b, a, b, 1\}$ form the universe of a subalgebra B of A such that $B \cong A_4$ or $B \cong D_5^a$. Observe that in both cases $\mathbb{S}(B) \cap \{A_4, B_4\} \neq \emptyset$. The case where 0 is not meet-prime is handled similarly, showing that either $A_5 \in \mathbb{S}(A)$ or $D_5^b \in \mathbb{S}(A)$.

It only remains to consider the case where 0 is meet-prime and 1 is join-prime. Together with the fact that A is different from C_2 and D_3 , this implies that it contains a four-element chain $0 < a < b < 1$. But this is the universe of a subalgebra of A isomorphic to B_4 . Hence we conclude that $B_4 \in \mathbb{S}(A)$ as desired. \boxtimes

As a consequence of the above result we obtain a characterization of the covers of $\mathbb{V}(D_3)$.

Corollary 8.3. $\mathbb{V}(D_4, D_3), \mathbb{V}(C_3^a, D_3), \mathbb{V}(C_3^b, D_3), \mathbb{V}(A_4), \mathbb{V}(B_4)$ are the unique covers of $\mathbb{V}(D_3)$ in the lattice of subvarieties of PS_4 .

Proof. From Jónsson's lemma it follows that the varieties listed in the statement are covers of $\mathbb{V}(D_3)$. Consider a subvariety K that covers $\mathbb{V}(D_3)$ in the lattice of subvarieties of PS_4 . We have two cases: either the equational theory in one variable of K is the same as the one of $\mathbb{V}(D_3)$ or not. First consider the case where it is the same. Since K covers $\mathbb{V}(D_3)$ there is $A \in K_{si} \setminus \{C_2, D_3\}$. By Lemma 8.2 we obtain that $K \cap \{A_4, B_4\} \neq \emptyset$. Since $\mathbb{V}(A_4)$ and $\mathbb{V}(B_4)$ are covers of $\mathbb{V}(D_3)$, we conclude that either $K = \mathbb{V}(A_4)$ or $K = \mathbb{V}(B_4)$. Then consider the case where the equational theory of K in one variable is different from the one of $\mathbb{V}(D_3)$. This means that K contains a one-generated subdirectly irreducible algebra A different from C_2 and D_3 . Together with the fact that K is a cover of $\mathbb{V}(D_3)$, this implies that $K = \mathbb{V}(A, D_3)$. Now, we know that A is one of the algebras depicted in Figure 2. It is easy to see that the unique algebras A in Figure 2 such that $\mathbb{V}(A, D_3)$ is a cover of $\mathbb{V}(D_3)$ are D_4, C_3^a and C_3^b . \boxtimes

It only remains to characterize the covers of $\mathbb{V}(\mathbf{C}_4^a)$ and $\mathbb{V}(\mathbf{C}_4^b)$. Since the algebras \mathbf{C}_4^a and \mathbf{C}_4^b are symmetric, we will detail the technical work only for $\mathbb{V}(\mathbf{C}_4^a)$, since the other one is completely analogous.

Lemma 8.4. $\mathbb{V}(\mathbf{C}_3^a)$ is axiomatized w.r.t. PS4 by the equational theory of \mathbf{C}_3^a in one variable.

Proof. Let \mathbf{K} be a variety of positive \mathbf{S}_4 -algebra, whose equational theory in one variable coincides with the one of \mathbf{C}_3^a . Our goal is to prove that $\mathbf{K} = \mathbb{V}(\mathbf{C}_3^a)$. First observe that \mathbf{K} properly extends $\mathbb{V}(\mathbf{C}_2)$, since $\mathbf{C}_3^a \not\models x \approx \Box x$. Then there is $A \in \mathbf{K}_{si} \setminus \{\mathbf{C}_2\}$.

We will prove that any such A is isomorphic to \mathbf{C}_3^a . First observe that for every $a \in A$,

$$\Box a = 0 \text{ and } \Diamond a = a \text{ for every } a \in A \setminus \{0, 1\}. \quad (14)$$

To prove this, consider $a \in A \setminus \{0, 1\}$. Observe that $\mathbf{C}_3^a \models \Diamond x \approx x, \Diamond \Box x \approx \Box x$. Together with the fact that the equational theory of \mathbf{K} in one variable is the same as the one of $\mathbb{V}(\mathbf{C}_3^a)$, this implies that $\Diamond a = a$ and that $\Box a$ is a fixed point of both modal operations. From Corollary 4.3 it follows that $\Box a \in \{0, 1\}$. Together with the fact that $a < 1$, this implies that $\Box a = 0$. This establishes (14).

We have two cases: either 1 is join-prime or not. If 1 is not join-prime, then there are $a, b < 1$ such that $a \vee b = 1$. Together with (14), this implies that

$$1 = \Box(a \vee b) \leq \Box a \vee \Diamond b = 0 \vee b = b$$

which contradicts the fact that $b < 1$. Hence we conclude that 1 is join-prime.

Then consider $a < b$ such that $\text{Cg}(a, b)$ is the monolith of A . We have that $b < 1$. To prove this, observe that if $b = 1$, then $\langle 0, 1 \rangle = \langle \Box a, \Box b \rangle \in \text{Cg}(a, b)$. This means that A is simple. Lemma 4.5, together with the fact that $A \models \Diamond x \approx x$, implies that $A = \{0, 1\}$. But this implies that $A = \mathbf{C}_2$, which is false by assumption. This establishes $b < 1$. Now, observe that, since 1 is join-prime, $A \setminus \{1\}$ form the universe of a sublattice L of $\langle A, \wedge, \vee \rangle$. We know that L contains at least the two elements $a < b$. We claim that $L = \{a, b\}$. Suppose the contrary towards a contradiction. Then L is a lattice of more than three elements. In particular, this implies that there is a congruence θ of L different from the identity relation and such that $\langle a, b \rangle \notin \theta$. Consider the equivalence relation ϕ on A whose blocks are the following:

$$\{1\} \text{ and } c/\theta \text{ for every } c \in L.$$

The fact that 1 is join-prime and (14) imply that ϕ is congruence of A . Moreover, ϕ is different from the identity relation and $\langle a, b \rangle \notin \phi$. This contradicts the fact that $\text{Cg}(a, b)$ is the monolith of A , thus establishing the claim. Hence $A = L \cup \{1\} = \{a, b, 1\}$. Hence A is the three-element chain, whose modal operations are determined by (14). We conclude that $A \cong \mathbf{C}_3^a$. \square

As a consequence of the above result we obtain a characterization of the covers of $\mathbb{V}(\mathbf{C}_3^a)$ and $\mathbb{V}(\mathbf{C}_3^b)$.

Corollary 8.5.

1. $\mathbb{V}(\mathbf{C}_3^b, \mathbf{C}_3^a)$, $\mathbb{V}(\mathbf{D}_3, \mathbf{C}_3^a)$, $\mathbb{V}(\mathbf{D}_4, \mathbf{C}_3^a)$ and $\mathbb{V}(\mathbf{C}_4^a)$ are the unique covers of $\mathbb{V}(\mathbf{C}_3^a)$ in the lattice of subvarieties of PS4.
2. $\mathbb{V}(\mathbf{C}_3^a, \mathbf{C}_3^b)$, $\mathbb{V}(\mathbf{D}_3, \mathbf{C}_3^b)$, $\mathbb{V}(\mathbf{D}_4, \mathbf{C}_3^b)$ and $\mathbb{V}(\mathbf{C}_4^b)$ are the unique covers of $\mathbb{V}(\mathbf{C}_3^b)$ in the lattice of subvarieties of PS4.

Proof. We detail the proof of 1, since the proof of 2 is analogous. From Jónsson's lemma it follows that the varieties listed in the statement are covers of $\mathbb{V}(\mathbf{C}_3^a)$. Consider a subvariety K that covers $\mathbb{V}(\mathbf{C}_3^a)$ in the lattice of subvarieties of PS4. By Lemma 8.4 we know that the equational theory of K in one variable differs from the one of $\mathbb{V}(\mathbf{C}_3^a)$. This means that K contains a one-generated subdirectly irreducible algebra A different from \mathbf{C}_2 and \mathbf{C}_3^a . Together with the fact that K is a cover of $\mathbb{V}(\mathbf{C}_3^a)$, this implies that $K = \mathbb{V}(A, \mathbf{C}_3^a)$. Now, we know that A is one of the algebras depicted in Figure 2. It is easy to see that the unique algebras A in Figure 2 such that $\mathbb{V}(A, \mathbf{D}_3)$ is a cover of $\mathbb{V}(\mathbf{C}_3^a)$ are \mathbf{D}_4 , \mathbf{D}_3 , \mathbf{C}_3^b and \mathbf{C}_4^a . \square

Figure 4 describes pictorially the bottom part of the lattice of varieties of positive S_4 -algebras. More precisely, we have the following:

Theorem 8.6. *Figure 4 represents all varieties of positive S_4 -algebras, which have height ≤ 4 in the lattice of subvarieties of PS4.*

Proof. This is a consequence of Theorem 6.2, Lemmas 6.1 and 8.1, and Corollaries 8.3 and 8.5. \square

9. STRUCTURAL COMPLETENESS

We conclude this study of varieties of positive modal algebras with some application to structural completeness. To this end, some observations are in order. In [57] Rybakov provided a full characterization of HSC varieties of K_4 -algebras. It turns out that they are all finitely axiomatizable and, therefore, that there are only countably many of them. Moreover, he showed that the map that associates to an intermediate logic its biggest modal companion preserves HSC [38, 57]. Keeping in mind that every variety of Gödel algebras is HSC [21], this implies that there are infinitely many HSC varieties of S_4 -algebras.⁴ These considerations show that there are infinitely many (but not uncountably many) HSC varieties of S_4 or, equivalently, K_4 -algebras.

It is interesting to compare this situation with the one occurring in the setting of positive K_4 -algebras, where we will show that there are only three non-trivial SC varieties (Theorem 9.7), that is SC almost never occur. Our first goal will be to prove that, in the study of SC in positive K_4 -algebras,

⁴Gödel algebra are simply the Heyting algebras, which are subdirect products of chains.

we can restrict harmlessly to positive S_4 -algebras (Corollary 9.3). To this end, we will rely on the following observation:

Lemma 9.1. $\mathbb{V}(\mathbf{B}_2)$ is the subvariety of PMA axiomatized by $\Box x \approx 1$ and $\Diamond x \approx 0$.

Proof. It is clear that the equations $\Box x \approx 1$ and $\Diamond x \approx 0$ holds in \mathbf{B}_2 and, therefore, in $\mathbb{V}(\mathbf{B}_2)$. Conversely, let A be a positive modal algebra in which these equations holds. Then consider any pair of different elements $a, b \in A$. We can assume w.l.o.g. that $a \not\leq b$. By the Prime Filter Theorem, there is $F \in \text{Pr}(A)$ such that $a \in F$ and $b \notin F$. Consider the map $f: A \rightarrow \mathbf{B}_2$ that sends to $1 \in \mathbf{B}_2$ exactly the elements which belong to F . Clearly f is a homomorphism of bounded lattices. Moreover, since the equations $\Box x \approx 1$ and $\Diamond x \approx 0$ hold in A , we conclude that f preserves also the modal operations. Thus every pair of different elements of A is separated by a homomorphism onto \mathbf{B}_2 . This means that $A \in \mathbb{P}_{\text{sd}}(\mathbf{B}_2)$ and, therefore, that $A \in \mathbb{V}(\mathbf{B}_2)$. \square

The next result highlights the importance of the algebra \mathbf{B}_2 for structural completeness in positive modal algebras.

Theorem 9.2. Let K be a SC variety of positive modal algebras. Either $K = \mathbb{V}(\mathbf{B}_2)$ or there are $n, m \geq 1$ such that

$$K \models \Box x \wedge \cdots \wedge \Box^n x \leq x \text{ and } K \models x \leq \Diamond x \vee \cdots \vee \Diamond^m x.$$

Proof. Let K be a SC variety of positive modal algebras. If K is trivial, then we are done. Then we can assume that K is non-trivial. By Lemma 2.1 we know that the free 0-generated algebra A over K is simple. We claim that either $A = \mathbf{B}_2$ or $A = \mathbf{C}_2$. To prove this, assume that $A \neq \mathbf{B}_2$. Then suppose towards a contradiction that $A \neq \mathbf{C}_2$. We have that either $0 < \Box 0$ or $\Diamond 1 < 1$. We detail the case where $0 < \Box 0$. Observe that if $\Box 0 = 1$, then

$$\Diamond 1 = \Diamond 1 \wedge \Box 0 \leq \Diamond(0 \wedge 1) = \Diamond 0 = 0.$$

But this implies that $A = \mathbf{B}_2$, which is false. Thus we have that $0 < \Box 0 < 1$. Consider the embedding $\kappa: A \rightarrow \mathcal{M}(A)$ described in Theorem 3.8. Then let F be the filter of $\mathcal{M}(A)$ generated by $\kappa(\Box 0)$. Observe that for every $b \in F$, we have that $\Box 0 \leq \Box b$ by the monotonicity of \Box . Thus we conclude that $F \in \text{Op}(\mathcal{M}(A))$. Consider the congruence $\phi := \{(b, c) \in A^2 : \langle \kappa(b), \kappa(c) \rangle \in \theta_F\}$ of A . We have that

$$\langle 0, \Box 0 \rangle \notin \phi \text{ and } \langle 1, \Box 0 \rangle \in \phi.$$

Thus we conclude that ϕ is different both from the identity and from the total relation, contradicting the fact that A is simple. The case where $\Diamond 1 < 1$ is handled similarly, with the only difference that one relies on the correspondence between the congruences of $\mathcal{M}(A)$ and its ideals closed under \Diamond . This establishes our claim.

Now, consider the case where $A = \mathbf{B}_2$. Clearly in K the equations $\Box x \approx 1$ and $\Diamond x \approx 0$ hold. By Lemma 9.1 we conclude that $K = \mathbb{V}(\mathbf{B}_2)$. Then

consider the case where $A \neq B_2$. From the claim it follows that $A = C_2$. Suppose towards a contradiction that either there is no $n \geq 1$ such that $K \models \Box x \wedge \dots \wedge \Box^n x \leq x$ or there is no $n \geq 1$ such that $K \models x \leq \Diamond x \vee \dots \vee \Diamond^n x$. We will detail only the first case, since the second one is analogous.

Consider the free 1-generated algebra $Fm_K(x)$ over K . Let $\kappa: Fm_K(x) \rightarrow \mathcal{M}(Fm_K(x))$ be the embedding defined in the proof of Theorem 3.8. Consider the set

$$F := \{a \in \mathcal{M}(Fm_K(x)) : \kappa(\llbracket \Box x \wedge \dots \wedge \Box^n x \rrbracket) \leq a \text{ for some } n \geq 1\}.$$

It is easy to see that F is a filter of $\mathcal{M}(Fm_K(x))$. Moreover, consider an arbitrary $a \in F$. Then there is $n \geq 1$ such that $\kappa(\llbracket \Box x \wedge \dots \wedge \Box^n x \rrbracket) \leq a$. We have that:

$$\begin{aligned} \kappa(\llbracket \Box^1 x \wedge \dots \wedge \Box^{n+1} x \rrbracket) &\leq \kappa(\llbracket \Box^2 x \wedge \dots \wedge \Box^{n+1} x \rrbracket) \\ &= \kappa(\Box \llbracket \Box x \wedge \dots \wedge \Box^n x \rrbracket) \\ &= \Box \kappa(\llbracket \Box x \wedge \dots \wedge \Box^n x \rrbracket) \\ &\leq \Box a. \end{aligned}$$

We conclude that $\Box a \in F$. This shows that F is indeed an open filter. Then let $\phi := \{\langle b, c \rangle \in Fm_K(x)^2 : \langle \kappa(b), \kappa(c) \rangle \in \theta_F\}$. Since $\kappa(\llbracket x \rrbracket) \notin F$ and $\kappa(\llbracket \Box x \rrbracket) \in F$, we have that

$$\Box(\llbracket x \rrbracket / \phi) = \llbracket 1 \rrbracket / \phi \text{ and } \llbracket x \rrbracket / \phi < \llbracket 1 \rrbracket / \phi.$$

By Birkhoff's Subdirect Representation Theorem, there is an onto homomorphism $f: Fm_K(x)/\phi \rightarrow B$ where B is subdirectly irreducible and $f(\llbracket x \rrbracket / \phi) < f(\llbracket 1 \rrbracket / \phi)$. By condition 3 of Theorem 1.1, we know that $B \in \mathbb{S}\mathbb{P}_v(Fm_K(\omega))$. This means that there is an ultrapower of $Fm_K(\omega)$ in which the following sentence holds:

$$\exists x(x < 1 \text{ and } \Box x \approx 1).$$

By Łos's Theorem [9, Theorem V.2.9], the above sentence holds in $Fm_K(\omega)$. Thus there is a term $t(x_1, \dots, x_n)$ such that

$$K \models \Box t(x_1, \dots, x_n) \approx 1 \text{ and } K \not\models t(x_1, \dots, x_n) \approx 1. \quad (15)$$

Then there is an algebra $C \in K$ and $a_1, \dots, a_n \in C$ such that $t^C(a_1, \dots, a_n) < 1$. Observe that all the basic operations of C are monotone. Thus an easy induction on the construction of t shows that

$$t^C(0, \dots, 0) \leq t^C(a_1, \dots, a_n) < 1.$$

Now, observe that B_2 is a two-element subalgebra of C . Hence we conclude that $t^C(0, \dots, 0) = 0$. In particular, this implies that $\Box^C t^C(0, \dots, 0) = \Box^C 0 = 0$. But this contradicts (15). \square

Corollary 9.3. *Let K be a SC variety of positive K_4 -algebras. Either $K = \mathbb{V}(B_2)$ or $K \subseteq \text{PS4}$.*

Proof. Suppose that $K \neq \mathbb{V}(B_2)$. By Theorem 9.2 there are $n, m \geq 1$ such that

$$K \models \Box x \wedge \cdots \wedge \Box^n x \leq x \text{ and } K \models x \leq \Diamond x \vee \cdots \vee \Diamond^m x.$$

Since $K \subseteq PK_4$, it satisfy $\Box x \wedge \cdots \wedge \Box^n x \approx \Box x$ and $\Diamond x \vee \cdots \vee \Diamond^m x \approx \Diamond x$. Hence we conclude that the equations $\Box x \leq x \leq \Diamond x$ hold in K . \square

In the light of Corollary 9.3, the only difficult part in understanding structural completeness in positive K_4 -algebras consists in characterizing the structurally complete varieties of S_4 -algebras. We begin by proving some negative results.

Lemma 9.4. *Every ASC variety of positive S_4 -algebras excludes C_3^a and C_3^b .*

Proof. Suppose towards a contradiction that there is an ASC variety $K \subseteq PS_4$ that contains either C_3^a or C_3^b . We detail the case where $C_3^b \in K$, since the other one is similar. By condition 1 of Theorem 1.1, we know that $C_3^b \times C_2 \in \mathbb{Q}(Fm_K(\omega))$. Observe that the congruence lattice of $C_3^b \times C_2$ has exactly four elements, namely the identity, the total relation and the two congruences corresponding to the projections associated with the product. In particular, this implies that either $C_3^b \in \mathbb{Q}(Fm_K(\omega))$ or $C_3^b \times C_2$ is subdirectly irreducible relative to $\mathbb{Q}(Fm_K(\omega))$. Recall that C_3^b is subdirectly irreducible in the absolute sense. Thus we conclude that

$$\text{either } C_3^b \in \mathbb{SP}_U(Fm_K(\omega)) \text{ or } C_3^b \times C_2 \in \mathbb{SP}_U(Fm_K(\omega)).$$

Consider the case where $C_3^b \in \mathbb{SP}_U(Fm_K(\omega))$. This means that C_3^b embeds into an ultrapower of $Fm_K(\omega)$, where the following first-order sentence holds:

$$\exists x(0 \neq x \neq 1 \text{ and } \Box x \approx x \text{ and } \Diamond x \approx 1).$$

By Łos's Theorem [9, Theorem V.2.9], the above sentence holds in $Fm_K(\omega)$ too. In particular, this implies that $C_3^b \in \mathbb{S}(Fm_K(\omega))$. Similarly, one shows that if $C_3^b \times C_2 \in \mathbb{SP}_U(Fm_K(\omega))$, then $C_3^b \times C_2 \in \mathbb{S}(Fm_K(\omega))$ as well. Hence we conclude that

$$\text{either } C_3^b \in \mathbb{S}(Fm_K(\omega)) \text{ or } C_3^b \times C_2 \in \mathbb{S}(Fm_K(\omega)).$$

In both cases, this implies that there is $[\varphi(x_1, \dots, x_n)] \in Fm_K(\omega)$ such that $[\varphi] < [1]$ and $\Diamond[\varphi] = [1]$. Now it is easy to prove by induction on terms that

$$[\psi] \leq [\Diamond x_1 \vee \cdots \vee \Diamond x_n]$$

for every $[\psi] \in Fm_K(x_1, \dots, x_n)$ such that $[\psi] \neq [1]$. In particular, this implies that $[\varphi] \leq [\Diamond x_1 \vee \cdots \vee \Diamond x_n]$ and, therefore, that

$$[1] = \Diamond[\varphi] \leq \Diamond[\Diamond x_1 \vee \cdots \vee \Diamond x_n] = [\Diamond x_1 \vee \cdots \vee \Diamond x_n].$$

Thus we conclude that

$$K \models \Diamond x_1 \vee \cdots \vee \Diamond x_n \approx 1. \quad (16)$$

Observe the equation in (16) is not valid in C_3^b , since $\diamond 0 \vee \dots \vee \diamond 0 = 0 \neq 1$. Thus we obtain a contradiction as desired. \square

Another negative result that turns out to be very useful is the following:

Lemma 9.5. *Every ASC variety of PS4 excludes D_3 .*

Proof. Suppose the contrary towards a contradiction that K is a ASC variety of PS4 that contains D_3 . By condition 1 of Theorem 1.1 we know that $D_3 \times C_2 \in \mathbb{Q}(Fm_K(\omega))$. An argument similar to the one applied in the proof of Lemma 9.4 shows that there is $n \in \omega$ such that either D_3 or $D_3 \times C_2$ embeds into $Fm_K(x_1, \dots, x_n)$. In both cases, this implies that there is $[\varphi] \in Fm_K(x_1, \dots, x_n)$ such that $[\varphi] < [1]$ and $\diamond[\varphi] = [1]$. Again, as in the proof of Lemma 9.4, this yields that $K \models \diamond x \approx 1$ which is false. \square

We are now ready to prove the main results of this section:

Theorem 9.6. *Let K be a non-trivial variety of positive S4-algebras. The following conditions are equivalent:*

- (i) K is actively structurally complete.
- (ii) K is structurally complete.
- (iii) K is hereditarily structurally complete.
- (iv) $K = \mathbb{V}(C_2)$ or $K = \mathbb{V}(D_4)$.
- (v) K satisfies the equations $\square \diamond x \approx \square x$ and $\diamond \square x \approx \diamond x$.

Proof. Clearly (iii) \Rightarrow (ii) and (ii) \Rightarrow (i). Moreover, the equivalence between (iv) and (v) is the content of Theorem 6.7.

(i) \Rightarrow (iv). By Lemmas 9.4 and 9.5 we know that K excludes C_3^a, C_3^b and D_3 . Together with Theorem 6.2, this implies that either $K = \mathbb{V}(C_2)$ or $D_4 \in K$. If $K = \mathbb{V}(C_2)$, we are done. Then consider the case where $D_4 \in K$. Lemma 8.1, together with the fact that K excludes C_3^a, C_3^b and D_3 , implies that $K = \mathbb{V}(D_4)$.

(iv) \Rightarrow (iii). By condition 4 of Theorem 1.1 We have to prove that every subquasi-variety of $\mathbb{V}(D_4)$ is a variety. Observe that the one-generated free algebra A in $\mathbb{V}(D_4)$ is the five-element chain $0 < a < b < c < 1$ where $a = \square b = \square c$ and $c = \diamond a = \diamond b$. It is easy to see that D_4 is a retract of A . Thus we conclude that D_4 is projective in $\mathbb{V}(D_4)$.

Now consider a non-trivial subquasi-variety K of $\mathbb{V}(D_4)$. Clearly $\mathbb{V}(K) = \mathbb{V}(C_2)$ or $K = \mathbb{V}(D_4)$. First consider the case where $K = \mathbb{V}(C_2)$. Clearly $C_2 \in K$, since K is non-trivial. Thus we have that

$$\mathbb{V}(C_2) = \mathbb{P}_{\text{sd}}(C_2) \subseteq \mathbb{P}_{\text{sd}}(K) = K.$$

Hence we conclude that $K = \mathbb{V}(C_2)$. Second consider the case where $K = \mathbb{V}(D_4)$. This means that $D_4 \in \mathbb{H}(K)$. Then there is an algebra $B \in K$ such that $D_4 \in \mathbb{H}(B)$. Since D_4 is projective in $\mathbb{V}(D_4)$, we conclude that $D_4 \in \mathbb{S}(B) \subseteq K$. Thus we have that

$$\mathbb{V}(D_4) = \mathbb{P}_{\text{sd}}(C_2, D_4) \subseteq \mathbb{P}_{\text{sd}}(K) = K.$$

This implies that $K = \mathbb{V}(D_4)$ and, therefore, we are done. \square

As a consequence we obtain a characterization of structurally complete varieties of positive K_4 -algebras:

Theorem 9.7. *Let K be a non-trivial variety of positive K_4 -algebras. The following conditions are equivalent:*

- (i) K is structurally complete.
- (ii) K is hereditarily structurally complete.
- (iii) $K = \mathbb{V}(\mathbf{B}_2)$ or $K = \mathbb{V}(\mathbf{C}_2)$ or $K = \mathbb{V}(\mathbf{D}_4)$.

Proof. Part (ii) \Rightarrow (i) is clear. (i) \Rightarrow (iii). Suppose that $K \neq \mathbb{V}(\mathbf{B}_2)$. Then $K \subseteq \text{PS4}$ by Corollary 9.3. Hence we can apply Theorem 9.6 obtaining that $K = \mathbb{V}(\mathbf{C}_2)$ or $K = \mathbb{V}(\mathbf{D}_4)$.

(iii) \Rightarrow (ii). By Theorem 3.5 we know that $\mathbb{V}(\mathbf{C}_2)$ and $\mathbb{V}(\mathbf{D}_4)$ are hereditarily structurally complete. Then consider the case where $K = \mathbb{V}(\mathbf{B}_2)$. Observe that $\mathbf{B}_2 \in \mathbb{S}(A)$ for every non-trivial $A \in \mathbb{V}(\mathbf{B}_2)$. This implies that the only subquasi-varieties of $\mathbb{V}(\mathbf{B}_2)$ are the trivial and the total ones. Hence we conclude that $\mathbb{V}(\mathbf{B}_2)$ is hereditarily structurally complete. \square

Problem 1. Are there ASC varieties of positive K_4 -algebras that are not SC?

We conclude this section by characterizing passive structural completeness in varieties of positive K_4 -algebras.

Theorem 9.8. *Let K be a non-trivial variety of positive K_4 -algebras. The following conditions are equivalent:*

- (i) K is passively structurally complete.
- (ii) Either $K = \mathbb{V}(\mathbf{B}_2)$ or $(\mathbf{Fm}_K(0) = \mathbf{C}_2$ and \mathbf{C}_2 is the unique simple member of K).
- (iii) Either $K = \mathbb{V}(\mathbf{B}_2)$ or $(\mathbf{Fm}_K(0) = \mathbf{C}_2$ and K excludes \mathbf{D}_3).
- (iv) Either $K = \mathbb{V}(\mathbf{B}_2)$ or

$$K \models \diamond 1 \approx 1, \Box 0 \approx 0, \diamond x \wedge \Box \diamond x \leq x \vee \Box x \vee \diamond \Box x.$$

Proof. (i) \Rightarrow (iii). The same argument described in the proof of Theorem 9.2 shows that $\mathbf{Fm}_K(0)$ is either \mathbf{B}_2 or \mathbf{C}_2 . If $\mathbf{Fm}_K(0) = \mathbf{B}_2$, then clearly $K \models \Box x \approx 1, \diamond x \approx 0$. By Lemma 9.1 this implies that $K = \mathbb{V}(\mathbf{B}_2)$. Then consider the case where $\mathbf{Fm}_K(0) = \mathbf{C}_2$. We have to prove that K excludes \mathbf{D}_3 . Suppose the contrary towards a contradiction. Then the following positive existential sentence holds in \mathbf{D}_3 :

$$\exists x(0 \approx \Box x \text{ and } \diamond x \approx 1).$$

By condition 2 of Theorem 1.1 we conclude that the above sentence holds in every non-trivial member of K . But this contradicts the fact that $\mathbf{C}_2 \in K$, since K is non-trivial.

(iii) \Rightarrow (ii). Suppose that $K \neq \mathbb{V}(\mathbf{B}_2)$. Then consider a simple algebra $A \in K$. By Corollary 4.3 we know that $\Box a = 0$ and $\diamond a = 1$ for every $a \in A \setminus \{0, 1\}$. This implies that if A has at least three elements, then

$D_3 \in \mathbb{S}(A)$. From the assumption we conclude that A has only two elements. In particular, this implies that $A \cong C_2$.

(ii) \Rightarrow (i). We detail the case where $K \neq \mathbb{V}(B_2)$, since the other one is analogous (and easier). By condition 2 of Theorem 1.1 it will be enough to show that if a positive existential sentence Φ holds in a non-trivial member of K , then Φ holds in every non-trivial member of K . To this end, consider such a sentence Φ and suppose that it holds in a non-trivial $A \in K$. Since Φ is a positive existential sentences, it has the form

$$\Phi = \exists x_1, \dots, x_n \Psi$$

where Ψ is a conjunction of disjunctions of equations in variables x_1, \dots, x_n . We know that there are elements a_1, \dots, a_n such that $A \models \Psi(a_1, \dots, a_n)$. Then let B be the subalgebra of A generated by a_1, \dots, a_n . It is clear that Φ holds in B too. It is well known that every non-trivial finitely generated algebra of finite type has a simple homomorphic image [34, pp. 153-154]. Together with the assumptions, this implies that $C_2 \in \mathbb{H}(B_2)$. Since positive existential sentences are preserved under homomorphic images, we conclude that Φ holds in C_2 . Since C_2 embeds into every non-trivial member of K , we obtain that Φ holds in every non-trivial member of K as desired.

The equivalence between (iii) and (iv) follows from Lemma 7.3. \square

The next example shows that there are infinitely many varieties of positive S_4 -algebras both with and without PSC.

Example 9.9. We begin by proving that there are infinitely many PSC varieties of positive S_4 -algebras. For every natural $n \geq 1$, consider the power-set Boolean algebra $\mathcal{P}(\{a_1, \dots, a_n\})$. We equip it with a modal operator \square defined as follows:

$$\square X = \begin{cases} X & \text{if } X = \{a_1, \dots, a_n\} \\ \emptyset & \text{if } a_1 \notin X \\ \{a_1\} & \text{otherwise} \end{cases}$$

for every $X \subseteq \{a_1, \dots, a_n\}$. It is easy to see that the resulting expansion A_n is an S_4 -algebra. We denote by A_n^- its positive reduct (with \diamond in the signature). Clearly $A_n^- \in \text{PS4}$. Applying the correspondence between congruences and open filters in S_4 -algebras to the definition of A_n , we conclude that A_n is subdirectly irreducible. Moreover, the fact that $\langle A, \wedge, \vee, 0, 1 \rangle$ is a Boolean lattice implies that the congruences of A_n^- preserve the set-theoretic complement operation. Thus the congruences of A_n and A_n^- coincide. In particular, this implies that the identity relation is meet-irreducible in $\text{Con} A_n^-$ and, therefore, that A_n^- is subdirectly irreducible.

Consider $n < m$. We know that A_n^- is subdirectly irreducible. Thus we can apply Jonsson's lemma, that on cardinality grounds yields that $A_m^- \notin \mathbb{V}(A_n^-)$. Hence we conclude that if $n \neq m$, then $\mathbb{V}(A_n^-) \neq \mathbb{V}(A_m^-)$. Thus there are infinitely many varieties of the form $\mathbb{V}(A_n^-)$ with $n \geq 1$. It

only remains to prove that these varieties are PSC. By Theorem 9.8 it will be enough to show that $\mathbb{V}(A_n^-)$ excludes D_3 for every $n \geq 1$. By Jónsson's lemma, this amounts to proving that $D_3 \notin \mathbb{HS}(A_n^-)$. Suppose towards a contradiction that $D_3 \in \mathbb{HS}(A_n^-)$, i.e., that there is a subalgebra B of A_n^- and a congruence $\theta \in \text{Con}B$ such that $D_3 \cong B/\theta$. Thus B/θ is a three element chain. Let b/θ be the intermediate element of this chain. We know that $\langle \Box b, 0 \rangle, \langle \Diamond b, 1 \rangle \in \theta$. Recall that $b \subseteq \{a_1, \dots, a_n\}$. Moreover, observe that $\emptyset \neq b \neq \{a_1, \dots, a_n\}$, otherwise B/θ would be the trivial algebra. We have two cases: either $a_1 \in b$ or $a_1 \notin b$. First we consider the case where $a_1 \in b$. By definition of A_n^- we have that

$$\Diamond \Box b = \Diamond \{a_1\} = \{a_1, \dots, a_n\} = 1^{A_n^-}.$$

But this implies that $\langle 1, 0 \rangle = \langle \Diamond \Box b, \Diamond 0 \rangle \in \theta$, contradicting the fact that B/θ is non-trivial. Then we consider the case where $a_1 \notin b$. Again the definition of A_n^- implies that

$$\Box \Diamond b = \Box \{a_2, \dots, a_n\} = \emptyset = 0^{A_n^-}.$$

But this implies that $\langle 0, 1 \rangle = \langle \Box \Diamond b, \Box 1 \rangle \in \theta$, contradicting the fact that B/θ is non-trivial. Hence we conclude that $D_3 \notin \mathbb{HS}(A_n^-)$ as desired. This shows that there are infinitely many PSC varieties of positive S_4 -algebras.

In order to construct infinitely many varieties of positive S_4 -algebras, that are not PSC, we reason as follows. For every $n \geq 2$, let A_n be the positive S_4 -algebra whose universe is the 2^n -element Boolean lattice and whose modal operations are defined as in condition (i) of Lemma 4.5. By Lemma 4.5 we know that each A_n is simple. Observe that Jónsson's lemma implies, on cardinality grounds, that if $n < m$ yields that $A_m^- \notin \mathbb{V}(A_n)$. Thus there are infinitely many varieties of the form $\mathbb{V}(A_n^-)$ with $n \geq 2$. Moreover, it is clear that $D_3 \in \mathbb{S}(A_n) \subseteq \mathbb{V}(A_n)$ for every $n \geq 2$. By Theorem 9.8 we conclude that the varieties of the form $\mathbb{V}(A_n)$ are not PSC. \square

APPENDIX

Let $\vdash_{\mathbf{K}}$ be the *local* consequence relation [37] associated with the normal modal logic \mathbf{K} . Then let $\vdash_{\mathbf{K}}^+$ be the restriction of $\vdash_{\mathbf{K}}$ to the set of positive modal formulas. The logic $\vdash_{\mathbf{K}}^+$ has been studied in [10, 19] under the name of *positive modal logic* (for short PML). In particular, in [10] PML was axiomatized by means of the Gentzen system $\mathcal{PM}\mathcal{L}$ mentioned in the introduction. The system $\mathcal{PM}\mathcal{L}$ was formulated as a consequence relation $\vdash_{\mathcal{PM}\mathcal{L}}$ on the following set of sequents:

$$\text{Seq} := \{ \Gamma \triangleright \varphi : \Gamma \cup \{ \varphi \} \text{ is a finite set of positive modal formulas} \}.$$

The relation between PML and $\vdash_{\mathcal{PM}\mathcal{L}}$ is as follows: for every set of formulas $\Gamma \cup \{ \varphi \}$ we have that

$$\Gamma \vdash_{\mathbf{K}}^+ \varphi \iff \text{there is a finite } \Delta \subseteq \Gamma \text{ s.t. } \emptyset \vdash_{\mathcal{PM}\mathcal{L}} \Delta \triangleright \varphi.$$

The Gentzen system \mathcal{PML} enjoys a strong relation with the variety of positive modal algebras. In order to explain this, we need to introduce some definition. Given a sequent $\Gamma \triangleright \varphi$ in Seq , where $\Gamma = \{\gamma_1, \dots, \gamma_n\}$, we define

$$\tau(\Gamma \triangleright \varphi) := \{\gamma_1 \wedge \dots \wedge \gamma_n \leq \varphi\}.$$

Moreover, given an equation $\varphi \approx \psi$ in the language of positive modal algebras, we define

$$\rho(\varphi \approx \psi) := \{\varphi \triangleright \psi, \psi \triangleright \varphi\}.$$

The maps τ and ρ can be extended to power sets by picking unions. In this way we obtain two maps

$$\tau: \mathcal{P}(Seq) \longleftrightarrow \mathcal{P}(Eq): \rho$$

where Eq is the set of equations in the language of positive S_4 -algebras. It turns out that the consequence relation $\vdash_{\mathcal{PML}}$ and the equational consequence \models_{PMA} relative to PMA are mutually interpretable in the following sense [30]. For every $\Sigma \cup \{\Gamma \triangleright \varphi\} \subseteq Seq$ and every $\varphi \approx \psi \in Eq$ we have that:

$$\begin{aligned} \Sigma \vdash_{\mathcal{PML}} \Gamma \triangleright \varphi &\iff \tau(\Sigma) \models_{\text{PMA}} \tau(\Gamma \triangleright \varphi) \\ \varphi \approx \psi &\iff \models_{\text{PMA}} \tau\rho(\varphi \approx \psi). \end{aligned}$$

In abstract algebraic logic [22, 15, 23] the relation described above is known as *algebraizability*. More precisely, the Gentzen system \mathcal{PML} is algebraizable in the sense of [55] (see also [8, 23, 51]) with equivalent algebraic semantics the variety PMA. This induces a dual isomorphism between the lattices of *varieties* of positive modal algebras and *axiomatic extensions* of \mathcal{PML} , i.e. extensions of \mathcal{PML} by means of rules of the form $\emptyset \vdash \Gamma \triangleright \varphi$. In particular, the variety of positive K_4 -algebras correspond to the axiomatic extension \mathcal{PML}_4 , obtained adding to \mathcal{PML} the axioms

$$\emptyset \vdash \rho(\Box x \leq \Box \Box x) \text{ and } \emptyset \vdash \rho(\Diamond \Diamond x \leq \Diamond x).$$

Observe that the dual isomorphism between varieties of positive modal algebras and axiomatic extensions of \mathcal{PML} preserves and reflects (active, passive) structural completeness. Thus Theorems 9.7 and 9.8 provide a characterization of the various kinds of structural completeness in the axiomatic extensions of \mathcal{PML}_4 .

Acknowledgements. We wish to thank to Prof. Josep Maria Font for providing several useful comments on a first draft of this paper. Moreover, special thanks are due to the anonymous referees for providing additional references and useful remarks, which helped to improve significantly the presentation. This research was supported by the joint project of Austrian Science Fund (FWF) I1897-N25 and Czech Science Foundation (GACR) GF15-34650L, and by project CZ.02.2.69/0.0/0.0/17.050/0008361, OPVVV MŠMT, MSCA-IF Lidské zdroje v teoretické informatice.

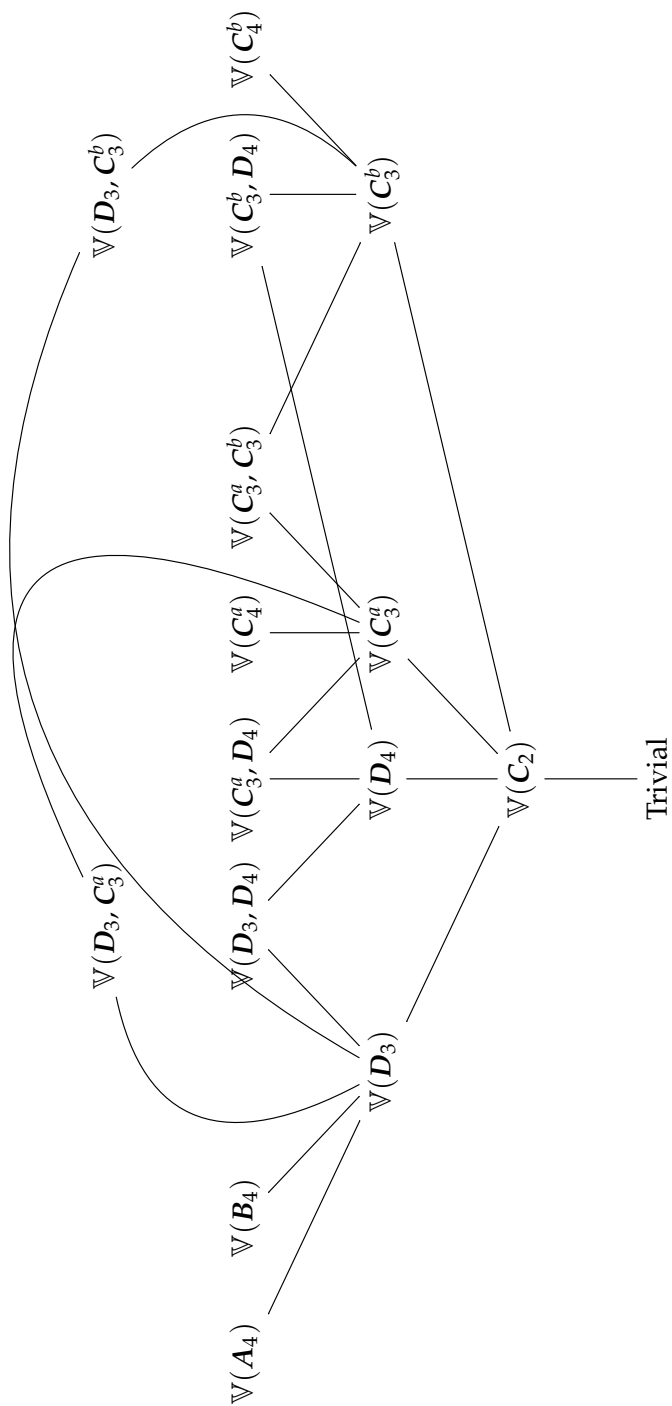

FIGURE 4. Some varieties of positive S_4 -algebras

REFERENCES

- [1] A. Balan, A. Kurz, and J. Velebil. Positive fragments of coalgebraic logics. *Logical Methods in Computer Science*, 11(3):1–51, 2015.
- [2] L. Beklemishev. Positive provability logic for uniform reflection principles. *Annals of Pure and Applied Logic*, 165(1):82–105, 2014.
- [3] L. Beklemishev. A Note on Strictly Positive Logics and Word Rewriting Systems. In *Larisa Maksimova on Implication, Interpolation, and Definability*, volume 15 of *Outstanding Contributions to Logic*, pages 61–70. Springer-Verlag, 2018.
- [4] C. Bergman. Structural completeness in algebra and logic. In *Algebraic logic (Budapest, 1988)*, volume 54 of *Colloq. Math. Soc. János Bolyai*, pages 59–73. North-Holland, Amsterdam, 1991.
- [5] C. Bergman. *Universal Algebra: Fundamentals and Selected Topics*. Chapman & Hall Pure and Applied Mathematics. Chapman and Hall/CRC, 2011.
- [6] G. Bezhanishvili and R. Grigolia. Locally tabular extensions of MIPC. In M. Zakharyashev, K. Segerberg, M. de Rijke, and H. Wansing, editors, *Advances in Modal Logic*, volume 2, pages 101–120, 2001.
- [7] P. Blackburn, M. de Rijke, and Y. Venema. *Modal logic*. Number 53 in Cambridge Tracts in Theoretical Computer Science. Cambridge University Press, Cambridge, 2001.
- [8] W. J. Blok and D. Pigozzi. *Algebraizable logics*, volume 396 of *Mem. Amer. Math. Soc. A.M.S.*, Providence, January 1989.
- [9] S. Burris and H. P. Sankappanavar. *A course in Universal Algebra*. The millennium edition, 2012.
- [10] S. A. Celani and R. Jansana. A new semantics for positive modal logic. *Notre Dame Journal of Formal Logic*, 38(1):1–18, 1997.
- [11] S. A. Celani and R. Jansana. Priestley duality, a Sahlqvist theorem and a Goldblatt-Thomason theorem for positive modal logic. *Logic Journal of the I.G.P.L.*, 7:683–715, 1999.
- [12] S. A. Celani. Simple and subdirectly irreducibles bounded distributive lattices with unary operators. *International Journal of Mathematics and Mathematical Sciences*, 2006:20, 2006.
- [13] A. Chagrov and M. Zakharyashev. *Modal Logic*, volume 35 of *Oxford Logic Guides*. Oxford University Press, 1997.
- [14] A. Citkin. On structurally complete superintuitionistic logics. *Soviet Mathematics Doklady*, 19:816–819, 1978.
- [15] J. Czelakowski. *Protoalgebraic logics*, volume 10 of *Trends in Logic—Studia Logica Library*. Kluwer Academic Publishers, Dordrecht, 2001.
- [16] J. Czelakowski and W. Dziobiak. Congruence distributive quasivarieties whose finitely subdirectly irreducible members form a universal class. *Algebra Universalis*, 27(1):128–149, 1990.
- [17] B. A. Davey and H. A. Priestley. *Introduction to lattices and order*. Cambridge University Press, New York, second edition, 2002.
- [18] A. Day. Splitting algebras and a weak notion of projectivity. *Algebra Universalis*, 5:153–162, 1975.
- [19] J. M. Dunn. Positive modal logic. *Studia Logica*, 55(2):301–317, 1995.
- [20] W. Dzik and M. Stronkowski. Almost structural completeness; an algebraic approach. *Annals of Pure and Applied Logic*, 167(7):525–556, July 2016.
- [21] W. Dzik and A. Wroński. Structural completeness of Gödel’s and Dummett’s propositional calculi. *Studia Logica*, 32:69–73, 1973.
- [22] J. M. Font. *Abstract Algebraic Logic - An Introductory Textbook*, volume 60 of *Studies in Logic - Mathematical Logic and Foundations*. College Publications, London, 2016.
- [23] J. M. Font and R. Jansana. *A general algebraic semantics for sentential logics*, volume 7 of *Lecture Notes in Logic*. A.S.L., second edition 2017 edition, 2009.

- [24] R. Freese, E. Kiss, and M. Valeriote. Universal Algebra Calculator. Available at: www.uacalc.org, 2011.
- [25] M. Gehrke, H. Nagahashi, and Y. Venema. A Sahlqvist theorem for distributive modal logic. *Annals of Pure and Applied Logic*, 131(1-3):65–102, 2005.
- [26] V. A. Gorbunov. Lattices of quasivarieties. *Algebra and Logic*, 15:275–288, 1976.
- [27] V. A. Gorbunov. *Algebraic theory of quasivarieties*. Siberian School of Algebra and Logic. Consultants Bureau, New York, 1998.
- [28] G. E. Hughes and M. J. Cresswell. *A new introduction to modal logic*. Routledge, London, 1996.
- [29] R. Iemhoff. On the admissible rules of intuitionistic propositional logic. *The Journal of Symbolic Logic*, 66(1):281–294, 2001.
- [30] R. Jansana. Full models for positive modal logic. *Mathematical Logic Quarterly*, 48(3):427–445, 2002.
- [31] E. Jeřábek. Admissible rules of modal logic. *Journal of Logic and Computation*, 15(4):73–92, 2005.
- [32] P. T. Johnstone. *Stone Spaces*, volume 3 of *Cambridge studies in advanced mathematics*. Cambridge University Press, 1982.
- [33] P. T. Johnstone. Vietoris Locales and Localic Semilattices. In *Continuous lattices and their Applications*, volume 101, pages 155–180. Marcel Dekker, 1985.
- [34] B. Jónsson. *Topics in universal algebra*, volume 250 of *Lecture Notes in Mathematics*. Springer-Verlag, Berlin, 1970.
- [35] P. Köhler and D. Pigozzi. Varieties with equationally definable principal congruences. *Algebra Universalis*, 11:213–219, 1980.
- [36] M. Kracht. *Tools and techniques in modal logic*, volume 142 of *Studies in Logic and the Foundations of Mathematics*. North-Holland Publishing Co., Amsterdam, 1999.
- [37] M. Kracht. Modal consequence relations. In *Handbook of Modal Logic*, volume 3, 491–545. Elsevier Science Inc., New York, NY, USA, 2006.
- [38] L. L. Maksimova and V. V. Rybakov. A lattice of normal modal logics. *Algebra and Logic*, 13:105–122, 1974.
- [39] A. I. Mal'cev. *The metamathematics of algebraic systems, collected papers: 1936-1967*. Amsterdam, North-Holland Pub. Co., 1971.
- [40] R. McKenzie. Equational bases and nonmodular lattice varieties. *Transactions of the American Mathematical Society*, 174:1–43, 1972.
- [41] R. N. McKenzie, G. F. McNulty, and W. F. Taylor. *Algebras, lattices, varieties. Vol. I*. The Wadsworth & Brooks/Cole Mathematics Series. Wadsworth & Brooks/Cole Advanced Books & Software, Monterey, CA, 1987.
- [42] J. C. C. McKinsey and A. Tarski. The algebra of topology. *Annals of Mathematics*, 45:141–191, 1944.
- [43] G. Metcalfe and C. Röthlisberger. Admissibility in finitely generated quasivarieties. *Logical Methods in Computer Science*, 9(2):1–19, 2013.
- [44] T. Moraschini, J. G. Raftery, and J. J. Wannenburg. Singly generated quasivarieties and residuated structures. Submitted manuscript, 2019.
- [45] L. A. Nguyen. Constructing the Least Models for Positive Modal Logic Programs. *Fundamenta Informaticae*, 42(2):29–60, 2000.
- [46] L. A. Nguyen. On the complexity of fragments of modal logics. In Kings College Publications, editor, *Advances in Modal Logic*, volume 5, pages 249–268, 2005.
- [47] J. S. Olson, J. G. Raftery, and C. J. van Alten. Structural completeness in substructural logics. *Logic Journal of the I.G.P.L.*, 16(5):455–495, 2008.
- [48] A. Palmigiano. Coalgebraic semantics for positive modal logic. In H. P. Gumm, editor, *Electronic Notes in Theoretical Computer Science*, volume 82. Elsevier, 2003.
- [49] H. A. Priestley. Representation of distributive lattices by means of ordered Stone spaces. *Bull. London Math. Soc.*, 2:186–190, 1970.

- [50] H. A. Priestley. Ordered topological spaces and the representation of distributive lattices. *Proceedings of the London Mathematical Society. Third Series*, 24:507–530, 1972.
- [51] J. G. Raftery. Correspondences between Gentzen and Hilbert systems. *The Journal of Symbolic Logic*, 71(3):903–957, 2006.
- [52] J. G. Raftery. Admissible Rules and the Leibniz Hierarchy. *Notre Dame Journal of Formal Logic*, 57(4):569–606, 2016.
- [53] J. G. Raftery and K. Świrydowicz. Structural completeness in relevance logics. *Studia Logica*, 104(3):381–387, 2016.
- [54] W. Rautenberg. *Klassische und nichtklassische Aussagenlogik*. Vieweg Verlag, 1979.
- [55] J. Rebagliato and V. Verdú. Algebraizable Gentzen systems and the deduction theorem for Gentzen systems. Mathematics Preprint Series 175, University of Barcelona, 1995.
- [56] L. Rieger. Zamerka o t. naz. svobodnyh algebrah s zamykaniem. *Czechoslovak Mathematical Journal*, 7:16–20, 1957.
- [57] V. V. Rybakov. Hereditarily structurally complete modals logics. *The Journal of Symbolic Logic*, 60(1):266–288, March 1995.
- [58] V. V. Rybakov. *Admissibility of logical inference rules*, volume 136 of *Studies in Logic*. Elsevier, Amsterdam, 1997.
- [59] A. Wroński. Overflow rules and a weakening of structural completeness. In *Rozwazania o Filozfii Prawdziwej. Jerezmu Perzanowskiemu Darze*, 67–71. Uniwersytetu Jagiellońskiego, Kraków, 2009.

E-mail address: moraschini@cs.cas.cz

INSTITUTE OF COMPUTER SCIENCE OF THE CZECH ACADEMY OF SCIENCE, PRAGUE, CZECH
REPUBLIC